



US006150687A

United States Patent [19]

[11] Patent Number: **6,150,687**

Noble et al.

[45] Date of Patent: ***Nov. 21, 2000**

[54] **MEMORY CELL HAVING A VERTICAL TRANSISTOR WITH BURIED SOURCE/DRAIN AND DUAL GATES**

5,006,909	4/1991	Kosa	357/23.6
5,010,386	4/1991	Groover, III	357/42
5,017,504	5/1991	Nishimuro et al.	437/40
5,021,355	6/1991	Dhong et al.	437/35
5,028,977	7/1991	Kenneth et al.	357/43
5,057,896	10/1991	Gotou	257/296
5,072,269	12/1991	Hieda	257/302
5,083,047	1/1992	Horie et al.	307/465

[75] Inventors: **Wendell P. Noble**, Milton, Vt.;
Leonard Forbes, Corvallis, Oreg.; **Kie Y. Ahn**, Chappaqua, N.Y.

[73] Assignee: **Micron Technology, Inc.**, Boise, Id.

(List continued on next page.)

[*] Notice: This patent issued on a continued prosecution application filed under 37 CFR 1.53(d), and is subject to the twenty year patent term provisions of 35 U.S.C. 154(a)(2).

FOREIGN PATENT DOCUMENTS

61-140170	6/1986	Japan	237/302
563066963A	3/1988	Japan	257/305
522661	9/1993	Japan	H01L 29/784

OTHER PUBLICATIONS

Banerjee, S.K., et al., "Characterization of Trench Transistors for 3-D Memories", 1986 Symposium on VLSI Technology, Digest of Technical Papers, San Diego, CA, 79-80 (May 28-30, 1986).

(List continued on next page.)

[21] Appl. No.: **08/889,462**

[22] Filed: **Jul. 8, 1997**

[51] Int. Cl.⁷ **H01L 27/108**

[52] U.S. Cl. **257/302; 257/330**

[58] Field of Search 257/302, 296,
257/304, 347, 330, 331, 332

Primary Examiner—Sara Crane
Attorney, Agent, or Firm—Schwegman, Lundberg, Woessner & Kluth, P.A.

[56] References Cited

U.S. PATENT DOCUMENTS

3,931,617	1/1976	Russell	340/173 R
4,020,364	4/1977	Kuijk	307/242
4,051,354	9/1977	Choate	235/312
4,604,162	8/1986	Sobczak	156/657
4,630,088	12/1986	Ogura et al.	357/23.6
4,663,831	5/1987	Birrittella et al.	29/576 E
4,673,962	6/1987	Chatterjee et al.	357/23.6
4,677,589	6/1987	Haskell et al.	365/149
4,701,423	10/1987	Szluk	437/57
4,716,314	12/1987	Mulder et al.	307/477
4,761,768	8/1988	Turner et al.	365/201
4,766,569	8/1988	Turner et al.	365/185
4,845,537	7/1989	Nishimura et al.	357/23.4
4,906,590	3/1990	Kanetaki et al.	437/52
4,920,065	4/1990	Chin et al.	437/52
4,949,138	8/1990	Nishimura	357/23.6
4,958,318	9/1990	Harari	365/149
4,965,651	10/1990	Wagner	357/42
4,987,089	1/1991	Roberts	437/34
5,001,526	3/1991	Gotou	357/23.6

[57] ABSTRACT

An integrated circuit and fabrication method includes a memory cell for a dynamic random access memory (DRAM). Vertically oriented access transistors are formed on semiconductor pillars on buried bit lines. Buried first and second gates are provided for each access transistor on opposing sides of the pillars. Buried word lines extend in trenches orthogonal to the bit lines. The buried word lines interconnect ones of the first and second gates. In one embodiment, unitary gates are interposed and shared between adjacent pillars for gating the transistors therein. In another embodiment, separate split gates are interposed between and provided to the adjacent pillars for separately gating the transistors therein. In one embodiment, the memory cell has a surface area that is approximately $4F^2$, where F is a minimum feature size. Bulk-semiconductor and semiconductor-on-insulator (SOI) embodiments are provided.

24 Claims, 13 Drawing Sheets

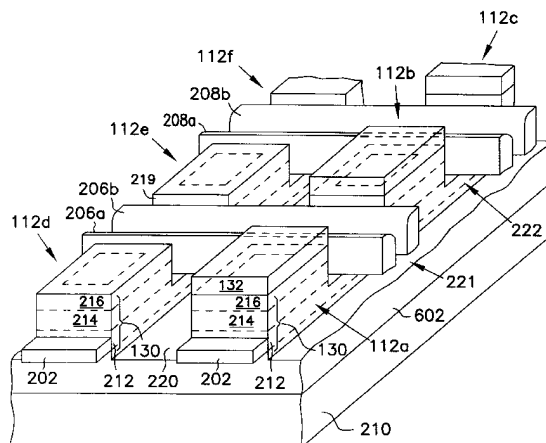

U.S. PATENT DOCUMENTS

5,087,581	2/1992	Rodder	437/41	5,827,765	10/1998	Stengl et al.	438/243
5,102,817	4/1992	Chatterjee et al.	437/47	5,834,814	11/1998	Ito	257/378
5,107,459	4/1992	Chu et al.	365/63	5,864,158	1/1999	Liu et al.	257/330
5,110,752	5/1992	Lu	437/47	5,877,061	3/1999	Halle et al.	438/386
5,156,987	10/1992	Sandhu et al.	437/40	5,907,170	5/1999	Forbes et al.	257/296
5,177,028	1/1993	Manning	437/41	5,909,400	6/1999	Bertin et al.	365/187
5,177,576	1/1993	Kimura et al.	257/71	5,909,618	6/1999	Forbes et al.	438/242
5,191,509	3/1993	Wen	361/311	5,914,511	6/1999	Noble et al.	257/302
5,202,278	4/1993	Mathews et al.	437/47	5,917,342	6/1999	Okamura	326/103
5,208,657	5/1993	Chatterjee et al.	257/302	5,920,088	7/1999	Augusto	257/192
5,216,266	6/1993	Ozaki	257/302	5,926,412	7/1999	Evans, Jr. et al.	365/145
5,221,867	6/1993	Mitra et al.	307/465	5,936,274	8/1999	Forbes et al.	257/315
5,223,081	6/1993	Doan	156/628	5,963,469	10/1999	Forbes	365/149
5,266,514	11/1993	Tuan et al.	437/52	5,973,352	10/1999	Noble	257/315
5,276,343	1/1994	Kumagai et al.	257/306	5,973,356	10/1999	Noble et al.	257/319
5,316,962	5/1994	Matsuo et al.	437/52	OTHER PUBLICATIONS			
5,320,880	6/1994	Sandhu et al.	427/578	Denton, J.P., et al., "Fully Depleted Dual-Gated Thin-Film SOI P-MOSFET's Fabricated in SOI Islands with an Isolated Buried Polysilicon Backgate", <i>IEEE Electron Device Letters</i> , 17, 509-511 (Nov. 1996).			
5,327,380	7/1994	Kersh, III et al.	365/195	Hisamoto, D., et al., "A New Stacked Cell Structure for Giga-Bit DRAMs using Vertical Ultra-Thin SOI (Delta) MOSFETs", <i>1991 IEEE International Electron Devices Meeting, Technical Digest</i> , Washington, D.C., 959-961 (Dec. 8-11, 1991).			
5,329,481	7/1994	Seevinck et al.	365/177	Kang, H.K., et al., "Highly Manufacturable Process Technology for Reliable 256 Mbit and 1Gbit DRAMs", <i>IEEE International Electron Devices Meeting, Technical Digest</i> , San Francisco, CA, 635-638 (Dec. 11-14, 1994).			
5,341,331	8/1994	Jeon	365/189.01	Kuge, S., et al., "SOI-DRAM Circuit Technologies for Low Power High Speed Multigiga Scale Memories", <i>IEEE Journal of Solid-State Circuits</i> , 31, 586-591 (Apr. 1996).			
5,376,575	12/1994	Kim et al.	437/52	Suma, K., et al., "An SOI-DRAM with Wide Operating Voltage Range by CMOS/SIMOX Technology", <i>IEEE Journal of Solid-State Circuits</i> , 29, 1323-1329 (Nov. 1994).			
5,378,914	1/1995	Ohzu et al.	257/369	Tanabe, N., et al., "A Ferroelectric Capacitor Over Bit-Line (F-COB) Cell for High Density Nonvolatile Ferroelectric Memories", <i>1995 Symposium on VLSI Technology</i> , Kyoto, Japan, 123-124 (Jun. 6-8, 1995).			
5,385,853	1/1995	Mohammad	437/41	Terauchi, M., et al., "A Surrounding Gate Transistor (SGT) Gain Cell for Ultra High Density DRAMs", <i>1993 Symposium on VLSI Technology</i> , Kyoto, Japan, 21-22 (May 17-19, 1993).			
5,391,911	2/1995	Beyer et al.	257/522	Wang, N., "Programmable Logic Arrays: PLAs" In: <i>Digital MOS Integrated Circuits</i> , Prentice Hall, Englewood Cliffs, NJ, pp. 328-333 (1989).			
5,392,245	2/1995	Manning	365/200	Watanbe, H., et al., "A New Cylindrical Capacitor Using Hemispherical Grained Si (HSG-Si) for 256Mb DRAMs", <i>1992 IEEE International Electron Devices Meeting, Technical Digest</i> , San Francisco, CA, 259-262 (Dec. 13-16, 1992).			
5,393,704	2/1995	Huang et al.	437/203	Adler, E., et al., "The Evolution of IBM CMOS DRAM Technology", <i>IBM Journal of Research and Development</i> , 39, 167-188 (Jan./Mar. 1995).			
5,396,093	3/1995	Lu	257/306	Asai, S., et al., "Technology Challenges for Integration Near and Below 0.1 μm ", <i>Proceedings of the IEEE</i> , 85, Special Issue on Nanometer-Scale Science & Technology, 505-520 (Apr. 1997).			
5,410,169	4/1995	Yamamoto et al.	257/301	Blalock, T.N., et al., "A High-Speed Sensing Scheme for 1T Dynamic RAM's Utilizing the Clamped Bit-Line Sense Amplifier", <i>IEEE Journal of Solid-State Circuits</i> , 27, 618-625 (Apr. 1992).			
5,414,287	5/1995	Hong	257/316	Bomchil, G., et al., "Porous Silicon: The Material and its Applications in Silicon-On-Insulator Technologies", <i>Applied Surface Science</i> , 41/42, 604-613 (1989).			
5,414,288	5/1995	Fitch et al.	257/328				
5,416,350	5/1995	Watanabe	257/350				
5,422,499	6/1995	Manning	257/67				
5,427,972	6/1995	Shimizu et al.	437/52				
5,432,739	7/1995	Pein	365/185				
5,438,009	8/1995	Yang et al.	437/52				
5,440,158	8/1995	Sung-Mu	257/314				
5,445,986	8/1995	Hirota	437/60				
5,460,316	10/1995	Hefele	228/39				
5,460,988	10/1995	Hong	437/43				
5,466,625	11/1995	Hsieh et al.	437/52				
5,483,094	1/1996	Sharma et al.	257/316				
5,483,487	1/1996	Sung-Mu	365/185.33				
5,492,853	2/1996	Jeng et al.	437/60				
5,495,441	2/1996	Hong	365/185.01				
5,497,017	3/1996	Gonzales	257/306				
5,504,357	4/1996	Kim et al.	257/306				
5,508,219	4/1996	Bronner et al.	437/52				
5,508,542	4/1996	Geiss et al.	257/301				
5,519,236	5/1996	Ozaki	257/302				
5,528,062	6/1996	Hsieh et al.	257/298				
5,563,083	10/1996	Pein	437/43				
5,574,299	11/1996	Kim	257/296				
5,581,101	12/1996	Ning et al.	257/347				
5,593,912	1/1997	Rajeevakumar	437/52				
5,616,934	4/1997	Dennison et al.	257/67				
5,627,097	5/1997	Venkatesan et al.	438/217				
5,627,390	5/1997	Maeda et al.	257/302				
5,637,898	6/1997	Baliga	257/330				
5,640,342	6/1997	Gonzalez	365/156				
5,644,540	7/1997	Manning	365/200				
5,646,900	7/1997	Tsukude et al.	365/205				
5,674,769	10/1997	Alsmeyer et al.	437/52				
5,691,230	11/1997	Forbes	437/62				
5,705,415	1/1998	Orlowski et al.	437/43				
5,707,885	1/1998	Lim	437/52				
5,719,409	2/1998	Singh et al.	257/77				
5,753,947	5/1998	Gonzalez	257/296				
5,760,434	6/1998	Zahurak et al.	257/309				
5,801,413	9/1998	Pan	257/301				
5,818,084	10/1998	Williams et al.	257/329				

- Burnett, D., et al., "Implications of Fundamental Threshold Voltage Variations for High-Density SRAM and Logic Circuits", 1994 Symposium on VLSI Technology, Digest of Technical Papers, Honolulu, HI, 15-16 (Jun. 4-7, 1994).
- Burnett, D., et al., "Statistical Threshold-Voltage Variation and its Impact on Supply-Voltage Scaling", *SPIE*, 2636, 83-90 (1995).
- Chen, M.-J., et al., "Back-Gate Forward Bias Method for Low-Voltage CMOS Digital Circuits", *IEEE Transactions on Electron Devices*, 43, 904-909 (Jun. 1986).
- Chen, M.-J., et al., "Optimizing the Match in Weakly Inverted MOSFET's by Gated Lateral Bipolar Action", *IEEE Transactions on Electron Devices*, 43, 766-773 (May 1996).
- Chung, I.-Y., et al., "A New SOI Inverter for Low Power Applications", Proceedings of the 1996 IEEE International SOI Conference, Sanibel Island, FL, 20-21 (Sep. 30-Oct. 3, 1996).
- De, V.K., et al., "Random MOSFET Parameter Fluctuation Limits to Gigascale Integration (GSI)", 1996 Symposium on VLSI Technology, Digest of Technical Papers, Honolulu, HI, 198-199 (Jun. 11-13, 1996).
- Fong, Y., et al., "Oxides Grown on Textured Single-Crystal Silicon—Dependence on Process and Application in EEPROMs", *IEEE Transactions on Electron Devices*, 37, 583-590 (Mar. 1990).
- Fuse, T., et al., "A 0.5V 200MHz 1-Stage 32b ALU Using a Body Bias Controlled SOI Pass-Gate Logic", 1997 IEEE International Solid-State Circuits Conference, Digest of Technical Papers, 286-287 (1997).
- Gong, S., et al., "Techniques for Reducing Switching Noise in High Speed Digital Systems", Proceedings of the 8th Annual IEEE International ASIC Conference and Exhibit, 21-24 (1995).
- Hao, M.-Y., et al., "Electrical Characteristics of Oxynitrides Grown on Textured Single-Crystal Silicon", *Appl. Phys. Lett.*, 60, 445-447 (Jan. 1992).
- Harada, M., et al., "Suppression of Threshold Voltage Variation in MTCMOS/SIMOX Circuit Operating Below 0.5 V", 1996 Symposium on VLSI Technology, Digest of Technical Papers, Honolulu, HI, 96-97 (Jun. 11-13, 1996).
- Hodges, D.A., et al., "MOS Decoders", In: *Analysis and Design of Digital Integrated Circuits, 2nd Edition*, McGraw-Hill Book Co., New York, 354-357 (1988).
- Holman, W.T., et al., "A Compact Low Noise Operational Amplifier for a 1.2 μm Digital CMOS Technology", *IEEE Journal of Solid-State Circuits*, 30, 710-714 (Jun. 1995).
- Hu, G., et al., "Will Flash Memory Replace Hard Disk Drive?", 1994 IEEE International Electron Device Meeting, Panel Discussion, Session 24, Outline, 1 p. (Dec. 13, 1994).
- Huang, W.L., et al., "TFSOI Complementary BiCMOS Technology for Low Power Applications", *IEEE Transactions on Electron Devices*, 42, 506-512 (Mar. 1995).
- Jun, Y.K., et al., "The Fabrication and Electrical Properties of Modulated Stacked Capacitor for Advanced DRAM Applications", *IEEE Electron Device Letters*, 13, 430-432 (Aug. 1992).
- Jung, T.-S., et al., "A 117-mm² 3.3-V Only 128-Mb Multilevel NAND Flash Memory for Mass Storage Applications", *IEEE Journal of Solid-State Circuits*, 31, 1575-1582 (Nov. 1996).
- Kim, Y.S., et al., "A Study on Pyrolysis DMEA for Selective Deposition of Aluminum", In: *Advanced Metallization and Interconnect Systems for ULSI Applications in 1995*, R.C. Ellwanger, et al., (eds.), Materials Research Society, Pittsburg, PA, 675-680 (1996).
- Kishimoto, T., et al., "Well Structure by High-Energy Boron Implantation for Soft-Error Reduction in Dynamic Random Access Memories (DRAMs)", *Japanese Journal of Applied Physics*, 34, 6899-6902 (Dec. 1995).
- Kohyama, Y., et al., "Buried Bit-Line Cell for 64MB DRAMs", 1990 Symposium on VLSI Technology, Digest of Technical Papers, Honolulu, HI, 17-18 (Jun. 4-7, 1990).
- Koshida, N., et al., "Efficient Visible Photoluminescence from Porous Silicon", *Japanese Journal of Applied Physics*, 30, L1221-L1223 (Jul. 1991).
- Lantz, II, L., "Soft Errors Induced by Alpha Particles", *IEEE Transactions on Reliability*, 45, 174-179 (Jun. 1996).
- Lehmann, V., "The Physics of Macropore Formation in Low Doped n-Type Silicon", *J. Electrochem. Soc.*, 140, 2836-2843 (Oct. 1993).
- Lu, N., et al., "The SPT Cell—A New Substrate-Plate Trench Cell for DRAMs", 1985 IEEE International Electron Devices Meeting, Technical Digest, Washington, D.C., 771-772 (Dec. 1-4, 1985).
- MacSweeney, D., et al., "Modelling of Lateral Bipolar Devices in a CMOS Process", *IEEE Bipolar Circuits and Technology Meeting*, Minneapolis, MN, 27-30 (Sep. 1996).
- Maeda, S., et al., "A Vertical ϕ -Shape Transistor ($V\phi T$) Cell for 1 Gbit DRAM and Beyond", 1994 Symposium of VLSI Technology, Digest of Technical Papers, Honolulu, HI, 133-134 (Jun. 7-9, 1994).
- Maeda, S., et al., "Impact of a Vertical ϕ -Shape Transistor ($V\phi T$) Cell for 1 Gbit DRAM and Beyond", *IEEE Transactions on Electron Devices*, 42, 2117-2123 (Dec. 1995).
- Malaviya, S., *IBM TBD*, 15, p. 42 (Jul. 1972).
- Nitayama, A., et al., "High Speed and Compact CMOS Circuits with Multipillar Surrounding Gate Transistors", *IEEE Transactions on Electron Devices*, 36, 2605-2606 (Nov. 1989).
- Ohno, Y., et al., "Estimation of the Charge Collection for the Soft-Error Immunity by the 3D-Device Simulation and the Quantitative Investigation", *Simulation of Semiconductor Devices and Processes*, 6, 302-305 (Sep. 1995).
- Oowaki, Y., et al., "New α -Particle Induced Soft Error Mechanism in a Three Dimensional Capacitor Cell", *IEICE Transactions on Electronics*, 78-C, 845-851 (Jul. 1995).
- Oshida, S., et al., "Minority Carrier Collection in 256 M-bit DRAM Cell on Incidence of Alpha-Particle Analyzed by Three-Dimensional Device Simulation", *IEICE Transactions on Electronics*, 76-C, 1604-1610 (Nov. 1993).
- Ozaki, T., et al., "A Surrounding Isolation-Merged Plate Electrode (Simple) Cell with Checkered Layout for 256Mbit DRAMs and Beyond", 1991 IEEE International Electron Devices Meeting, Washington, D.C., 469-472 (Dec. 8-11, 1991).
- Parke, S.A., et al., "A High-Performance Lateral Bipolar Transistor Fabricated on SIMOX", *IEEE Electron Device Letters*, 14, 33-35 (Jan. 1993).
- Pein, H., et al., "A 3-D Sidewall Flash EPROM Cell and Memory Array", *IEEE Transactions on Electron Devices*, 40, 2126-2127 (Nov. 1993).
- Pein, H., et al., "Performance of the 3-D Pencil Flash EPROM Cell and Memory Array", *IEEE Transactions on Electron Devices*, 42, 1982-1991 (Nov. 1995).

- Pein, H.B., et al., "Performance of the 3-D Sidewall Flash EPROM Cell", *IEEE International Electron Devices Meeting, Technical Digest*, 11-14 (1993).
- Rao, K.V., et al., "Trench Capacitor Design Issues in VLSI DRAM Cells", *1986 IEEE International Electron Devices Meeting, Technical Digest*, Los Angeles, CA, 140-143 (Dec. 7-10, 1986).
- Richardson, W.F., et al., "A Trench Transistor Cross-Point DRAM Cell", *1985 IEEE International Electron Devices Meeting*, Washington, D.C., 714-717 (Dec. 1-4, 1985).
- Sagara, K., et al., "A 0.72 μm^2 Recessed STC (RSTC) Technology for 256Mbit DRAMs using Quarter-Micron Phase-Shift Lithography", 1992 Symposium on VLSI Technology, Digest of Technical Papers, Seattle, WA, 10-11 (Jun. 2-4, 1992).
- Saito, M., et al., "Technique for Controlling Effective V_{th} in Multi-Gbit DRAM Sense Amplifier", 1996 Symposium on VLSI Circuits, Digest of Technical Papers, Honolulu, HI, 106-107 (Jun. 13-15, 1996).
- Shah, A.H., et al., "A 4-Mbit DRAM with Trench-Transistor Cell", *IEEE Journal of Solid-State Circuits*, SC-21, 618-625 (Oct. 1986).
- Shah, A.H., et al., "A 4Mb DRAM with Cross-Point Trench Transistor Cell", 1986 IEEE International Solid-State Circuits Conference, Digest of Technical Papers, 268-269 (Feb. 21, 1986).
- Sherony, M.J., et al., "Reduction of Threshold Voltage Sensitivity in SOI MOSFET's", *IEEE Electron Device Letters*, 16, 100-102 (Mar. 1995).
- Shimomura, K., et al., "A IV 46ns 16Mb SOI-DRAM with Body Control Technique", 1997 IEEE International Solid-State Circuits Conference, Digest of Technical Papers, 68-69 (Feb. 6, 1997).
- Stellwag, T.B., et al., "A Vertically-Integrated GaAs Bipolar DRAM Cell", *IEEE Transactions on Electron Devices*, 38, 2704-2705 (Dec. 1991).
- Sunouchi, K., et al., "A Surrounding Gate Transistor (SGT) Cell for 64/256Mbit DRAMs", *1989 IEEE International Electron Devices Meeting, Technical Digest*, Washington, D.C., 23-26 (Dec. 3-6, 1989).
- Sunouchi, K., et al., "Process Integration for 64M DRAM Using an Asymmetrical Stacked Trench Capacitor (AST) Cell", *1990 IEEE International Electron Devices Meeting*, San Francisco, CA 647-650 (Dec. 9-12, 1990).
- Takai, M., et al., "Direct Measurement and Improvement of Local Soft Error Susceptibility in Dynamic Random Access Memories", *Nuclear Instruments & Methods in Physics Research*, B-99, Proceedings of the 13th International Conference on the Application of Accelerators in Research and Industry, Denton, TX, 562-565 (Nov. 7-10, 1994).
- Takato, H., et al., "High Performance CMOS Surrounding Gate Transistor (SGT) for Ultra Density LSIs", *1988 IEEE International Electron Devices Meeting, Technical Digest*, 222-225 (1988).
- Takato, H., et al., "Impact of Surrounding Gate Transistor (SGT) for Ultra-High Density LSI's", *IEEE Transactions on Electron Devices*, 38, 573-578 (Mar. 1991).
- Temmler, D., "Multilayer Vertical Stacked Capacitors (MVSTC) for 64Mbit and 256Mbit DRAMs", 1991 Symposium on VLSI Technology, Digest of Technical Papers, Oiso, 13-14 (May 28-30, 1991).
- Tsui, P.G.Y., et al., "A Versatile Half-Micron Complementary BiCMOS Technology for Microprocessor-Based Smart Power Applications", *IEEE Transactions on Electron Devices*, 42, 564-570 (Mar. 1995).
- Verdonck-Vandebroek, S., et al., "High-Gain Lateral Bipolar Action in a MOSFET Structure", *IEEE Transactions on Electron Devices*, 38, 2487-2496 (Nov. 1991).
- Wang, P.W., et al., "Excellent Emission Characteristics of Tunneling Oxides Formed Using Ultrathin Silicon Films for Flash Memory Devices", *Japanese Journal of Applied Physics*, 35, 3369-3373 (Jun. 1996).
- Watanabe, H., et al., "A Novel Stacked Capacitor with Porous-Si Electrodes for High Density DRAMs", 1993 Symposium on VLSI Technology, Digest of Technical Papers, Kyoto, Japan, 17-18 (1993).
- Watanabe, H., et al., "An Advanced Fabrication Technology of Hemispherical Grained (HSG) Poly-Si for High Capacitance Storage Electrodes", Extended Abstracts of the 1991 International Conference on Solid State Devices and Materials, Yokohama, Japan, 478-480 (1991).
- Watanabe, H., et al., "Device Application and Structure Observation for Hemispherical-Grained Si", *J. Appl. Phys.*, 71, 3538-3543 (Apr. 1992).
- Watanabe, H., et al., "Hemispherical Grained Silicon (HSG-Si) Formation on In-Situ Phosphorous Doped Amorphous-Si Using the Seeding Method", Extended Abstracts of the 1992 International Conference on Solid State Devices and Materials, Tsukuba, Japan, 422-424 (1992).
- Watanabe, S., et al., "A Novel Circuit Technology with Surrounding Gate Transistors (SGT's) for Ultra High Density DRAM's", *IEEE Journal of Solid-State Circuits*, 30, 960-971 (Sep. 1995).
- Yamada, T., et al., "A New Cell Structure with a Spread Source/Drain (SSD) MOSFET and a Cylindrical Capacitor for 64-Mb DRAM's", *IEEE Transactions on Electron Devices*, 38, 2481-2486 (Nov. 1991).
- Yamada, T., et al., "Spread Source/Drain (SSD) MOSFET Using Selective Silicon Growth for 64Mbit DRAMs", *1989 IEEE International Electron Devices Meeting, Technical Digest*, Washington, D.C., 35-38 (Dec. 3-6, 1989).
- Yoshikawa, K., "Impact of Cell Threshold Voltage Distribution in the Array of Flash Memories on Scaled and Multilevel Flash Cell Design", 1996 Symposium on VLSI Technology, Digest of Technical Papers, Honolulu, HI, 240-241 (Jun. 11-13, 1996).

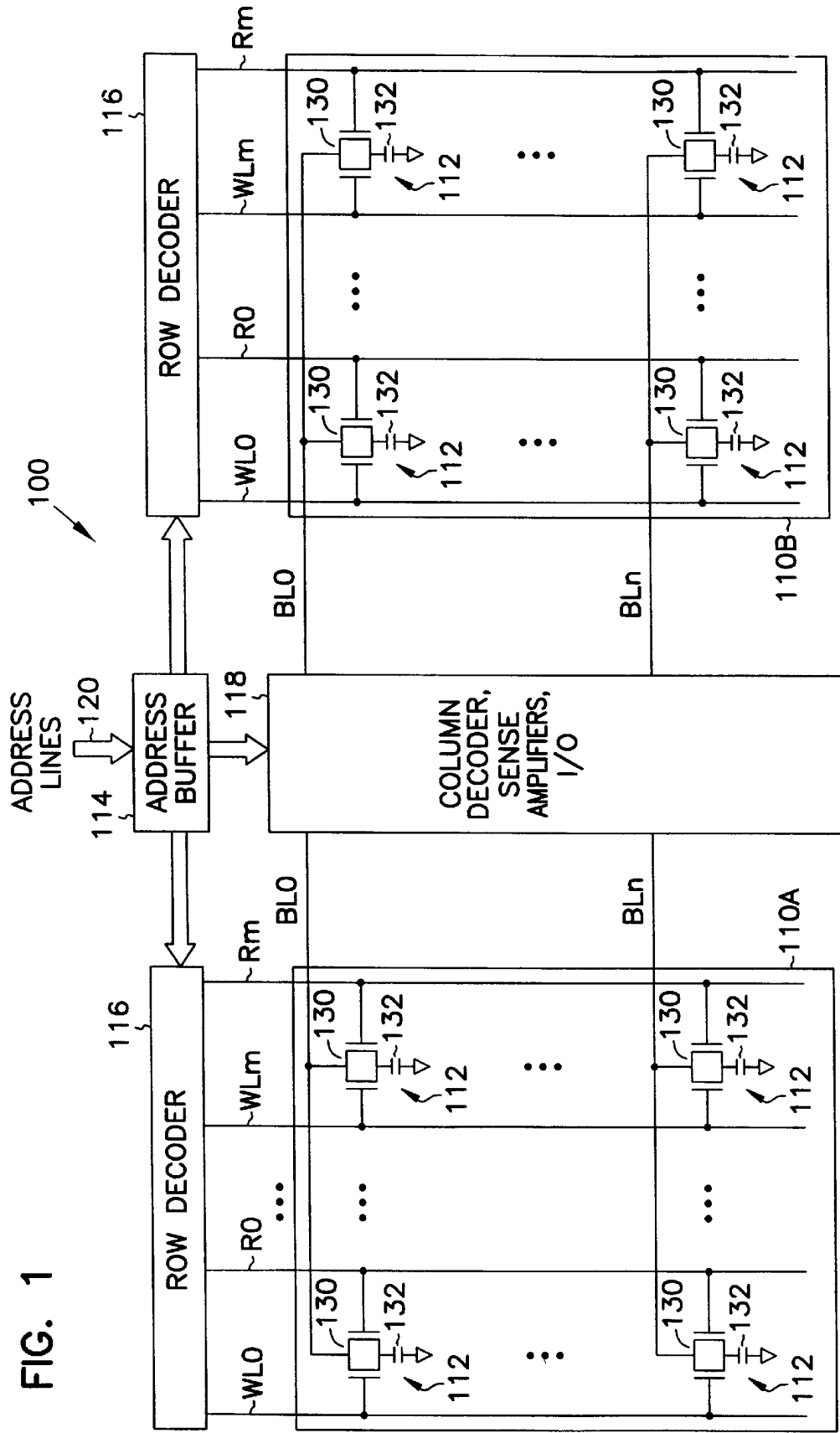

FIG. 1

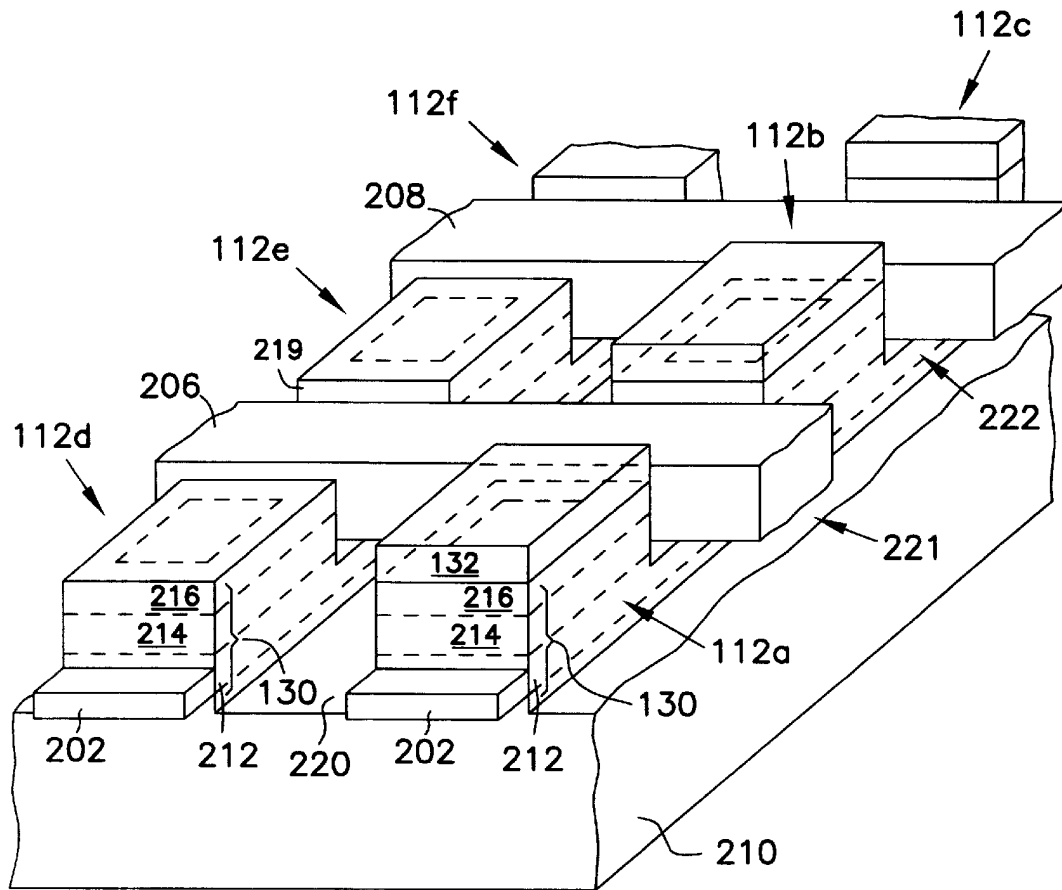

FIG. 2

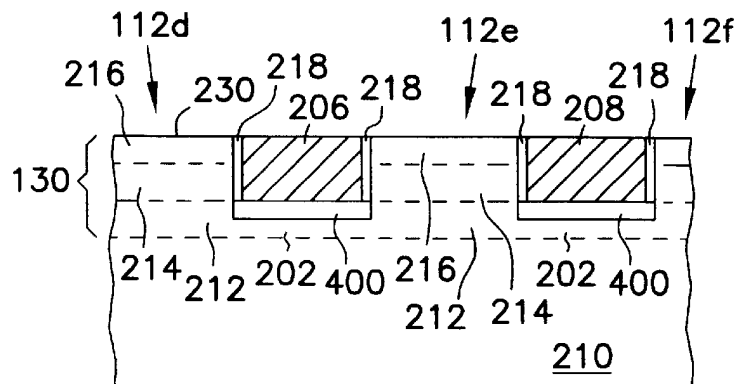

FIG. 4

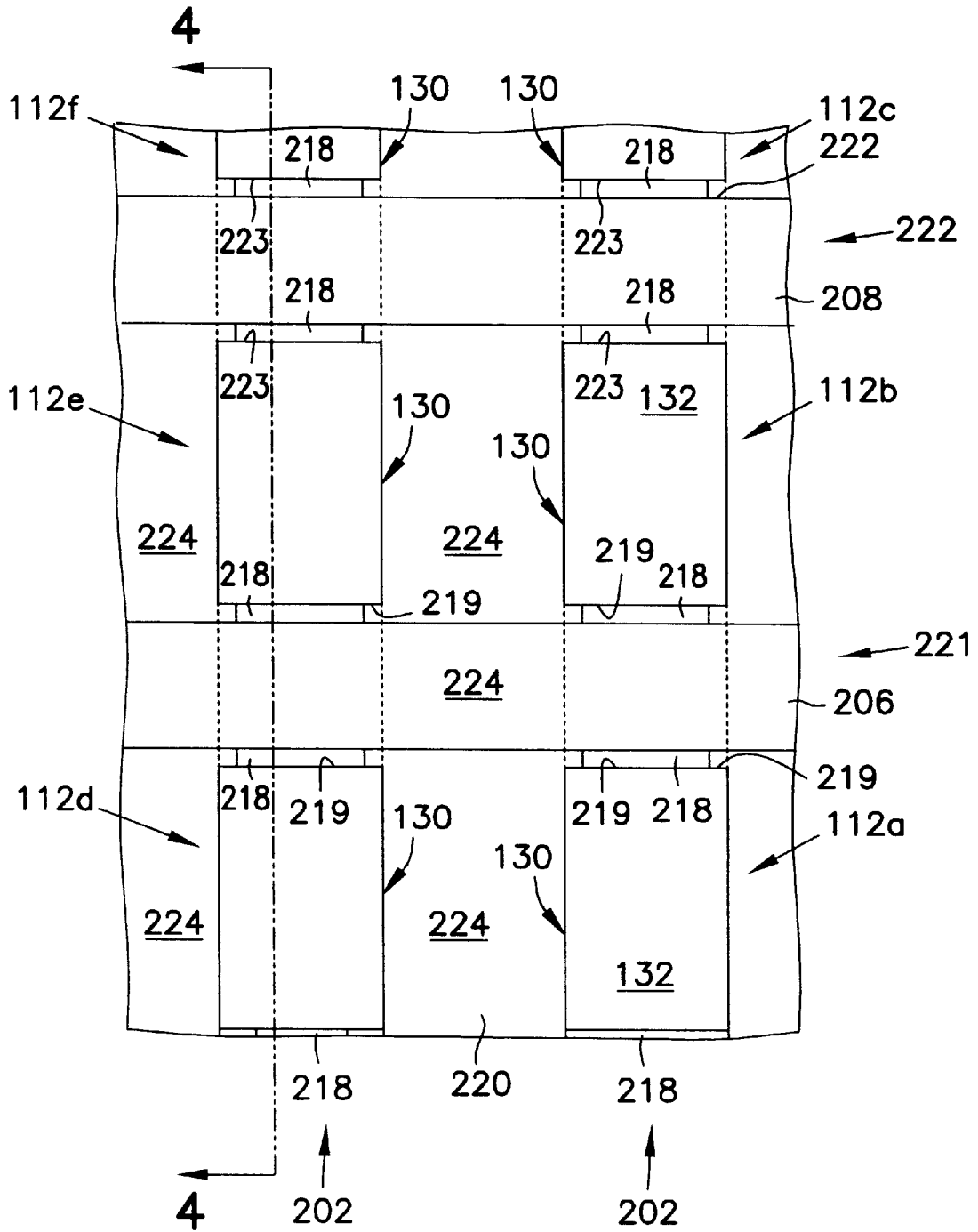

FIG. 3

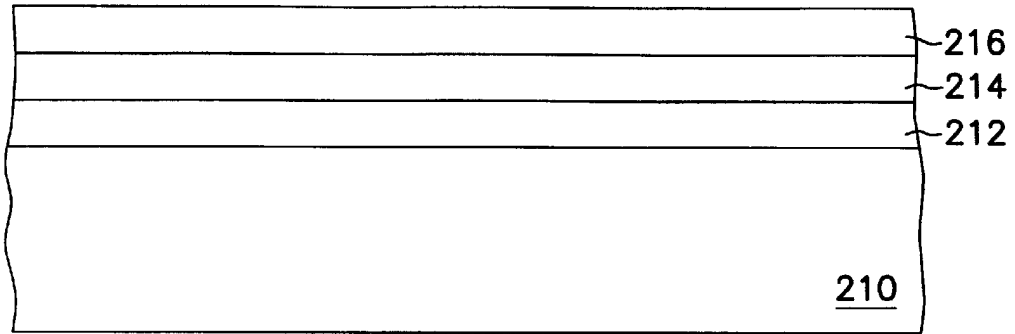

FIG. 5A

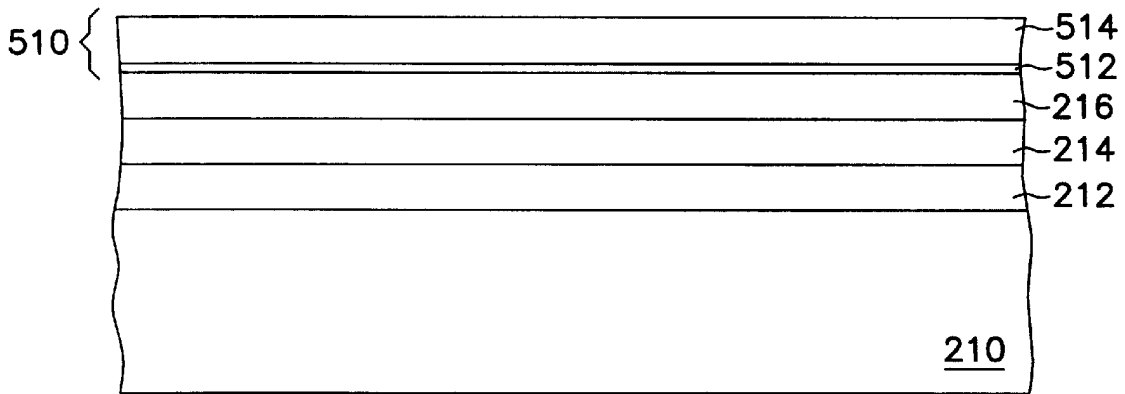

FIG. 5B

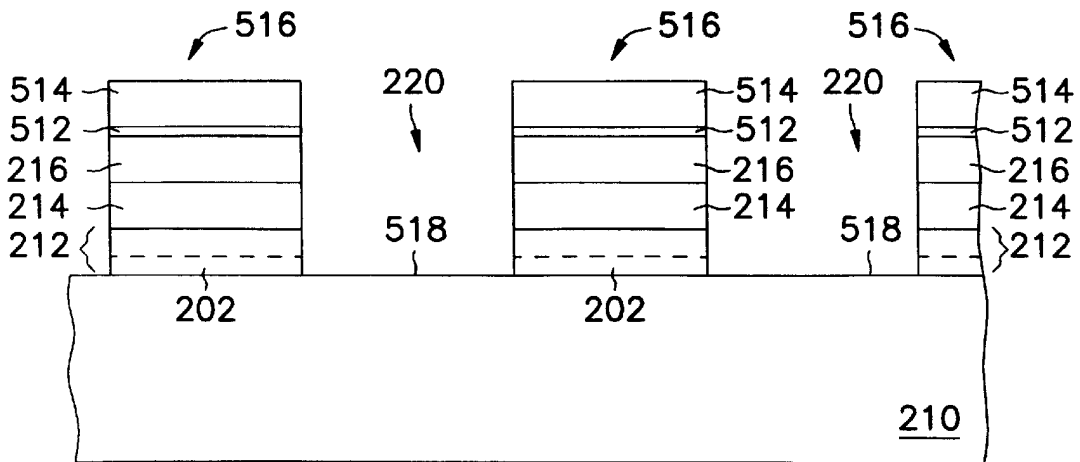

FIG. 5C

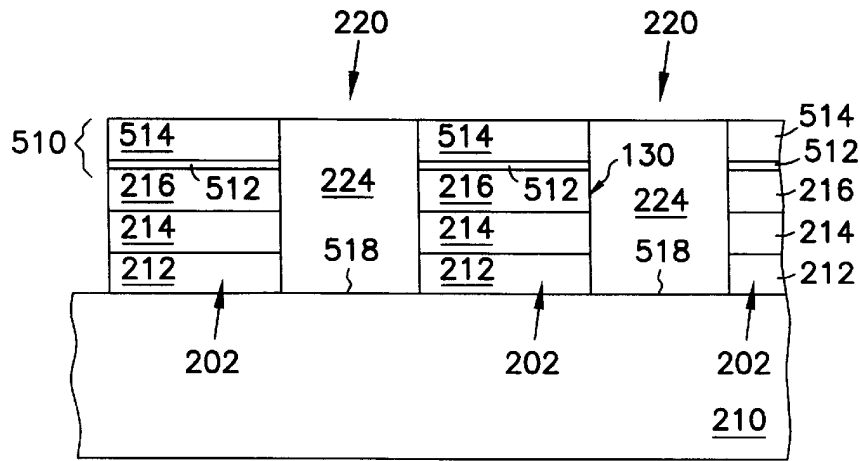

FIG. 5D

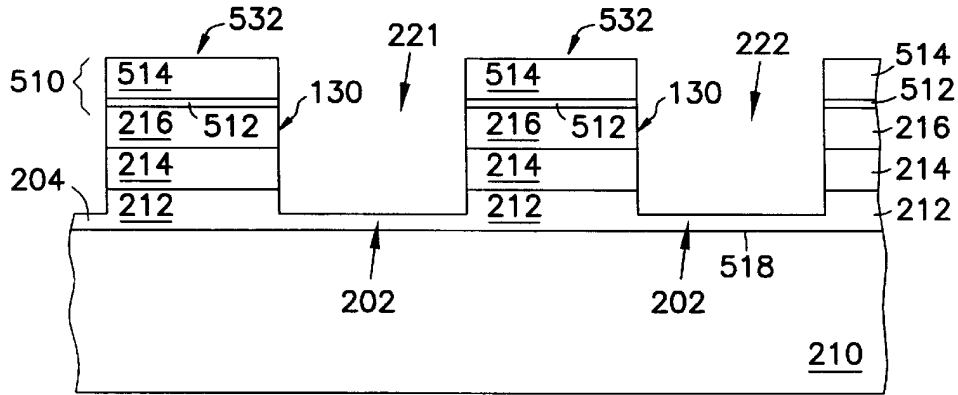

FIG. 5E

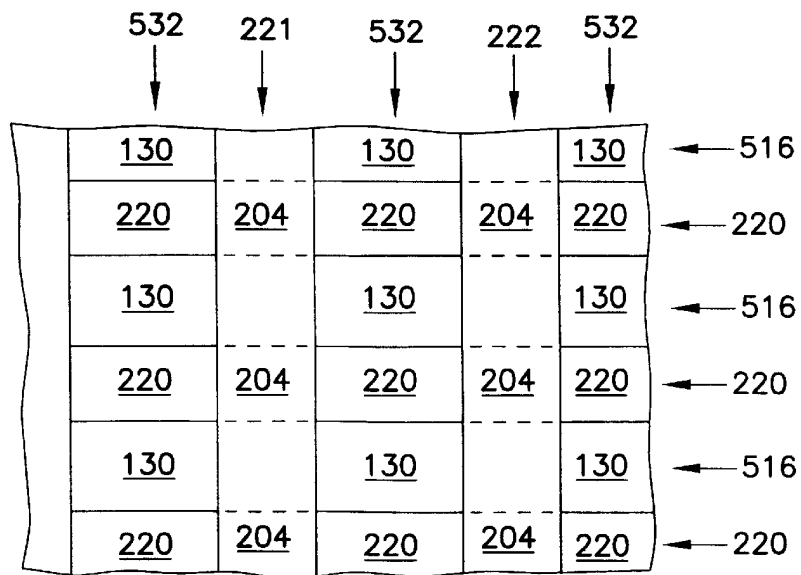

FIG. 5F

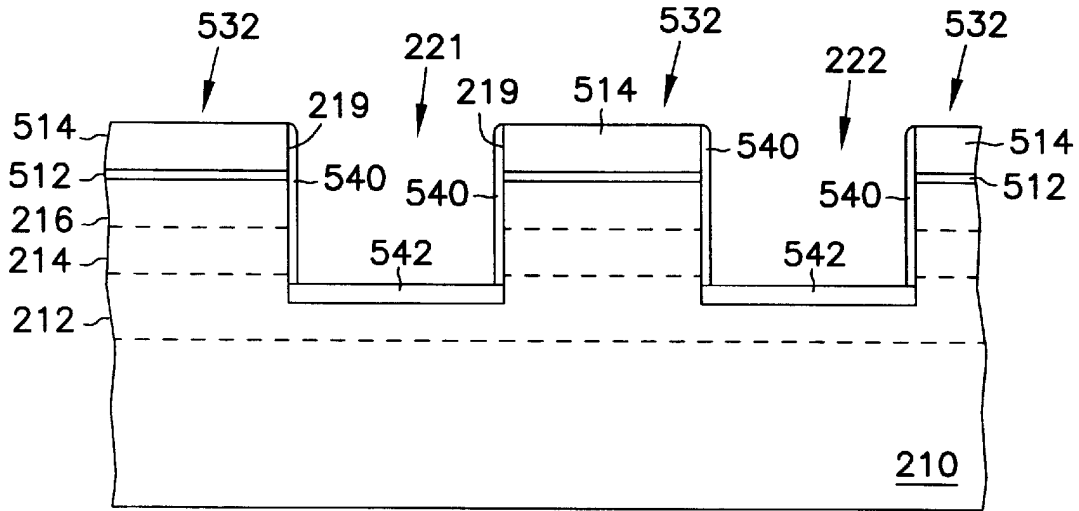

FIG. 5G

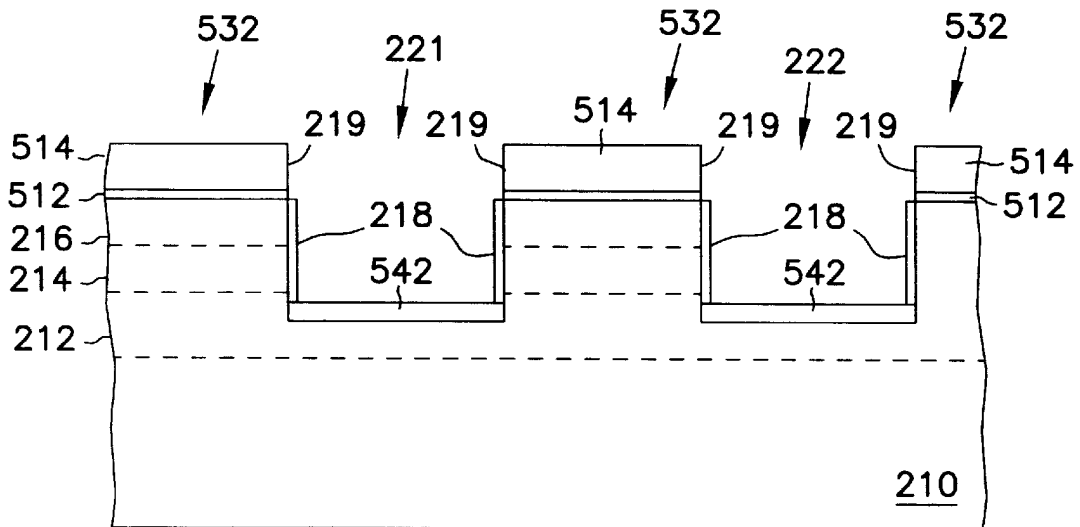

FIG. 5H

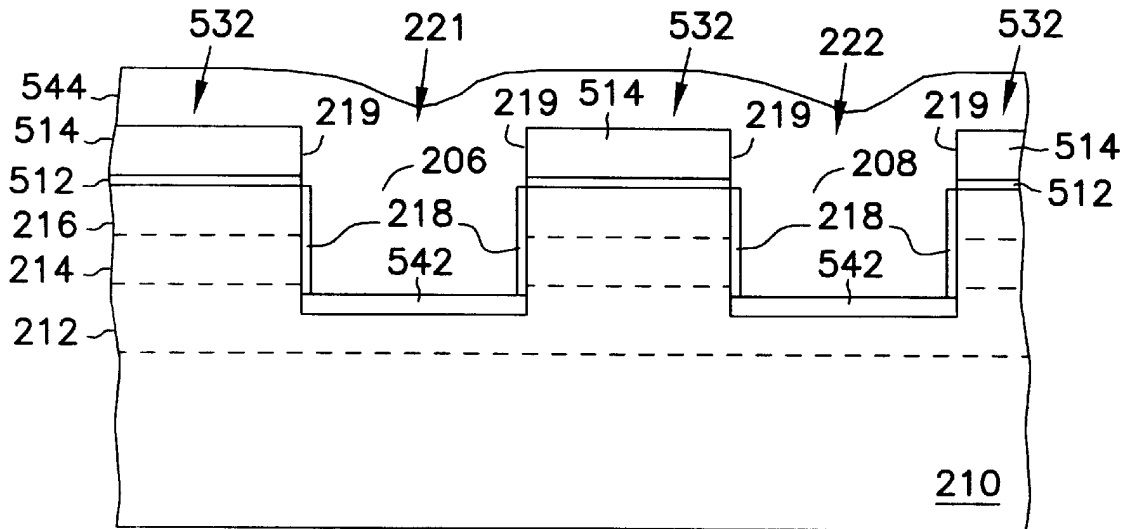

FIG. 5I

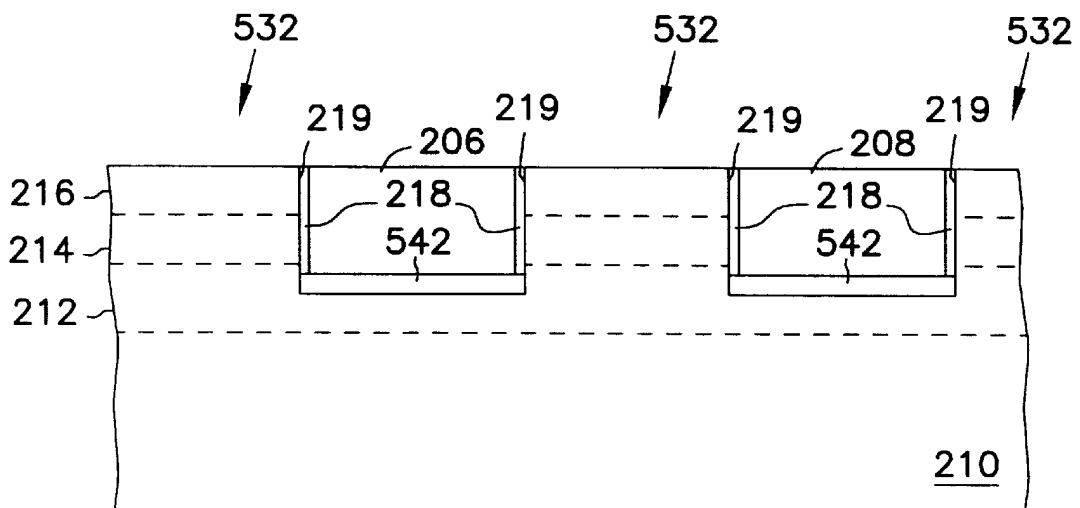

FIG. 5J

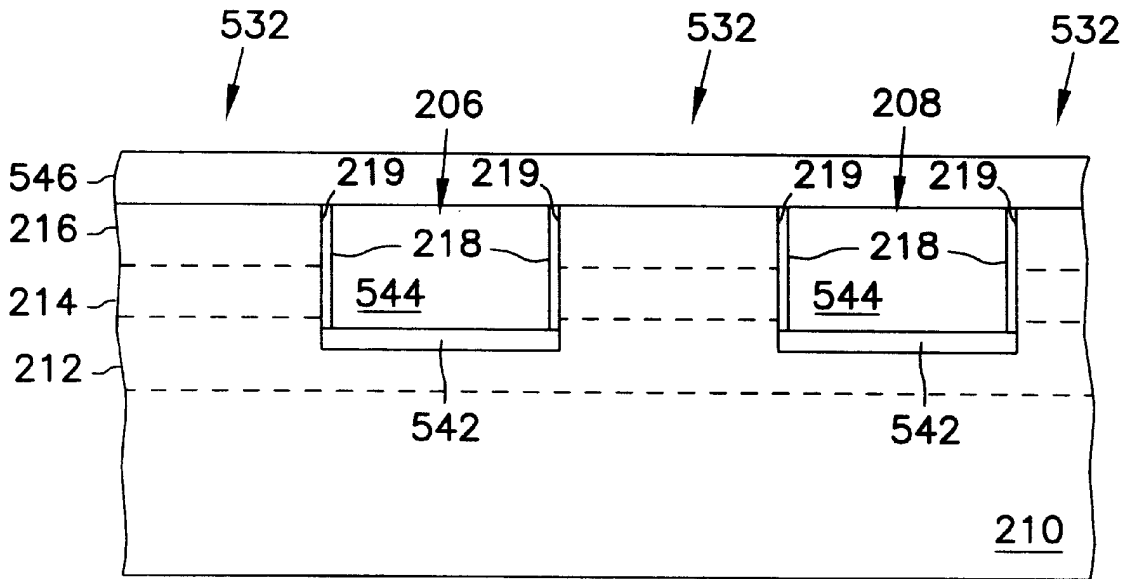

FIG. 5K

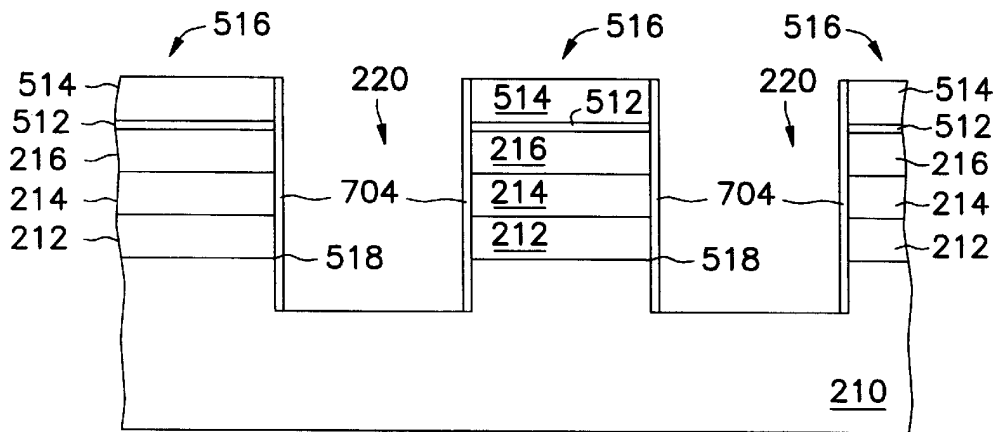

FIG. 7A

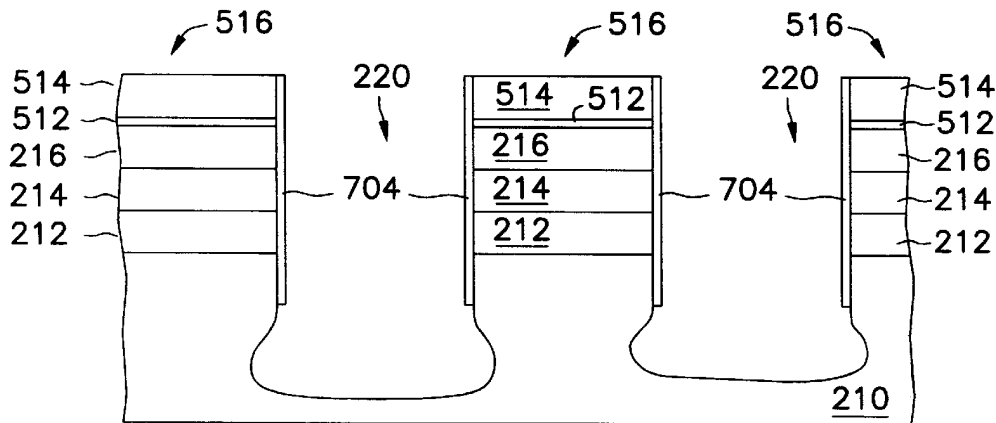

FIG. 7B

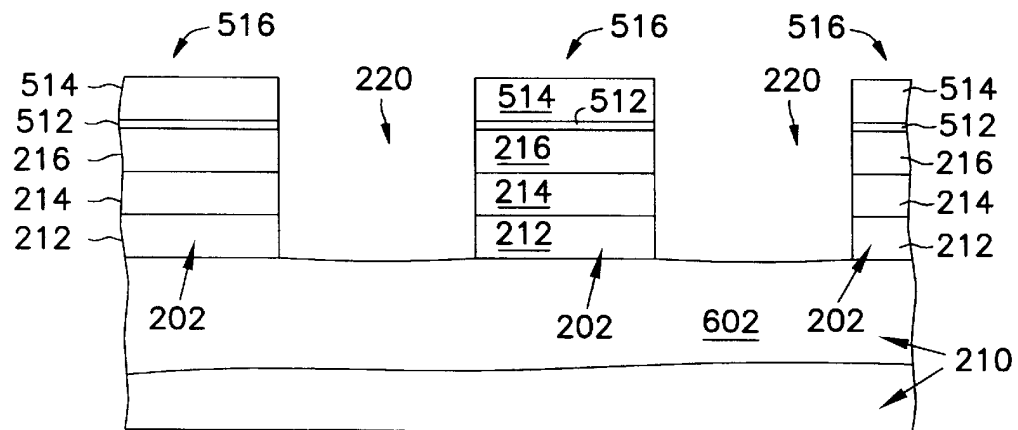

FIG. 7C

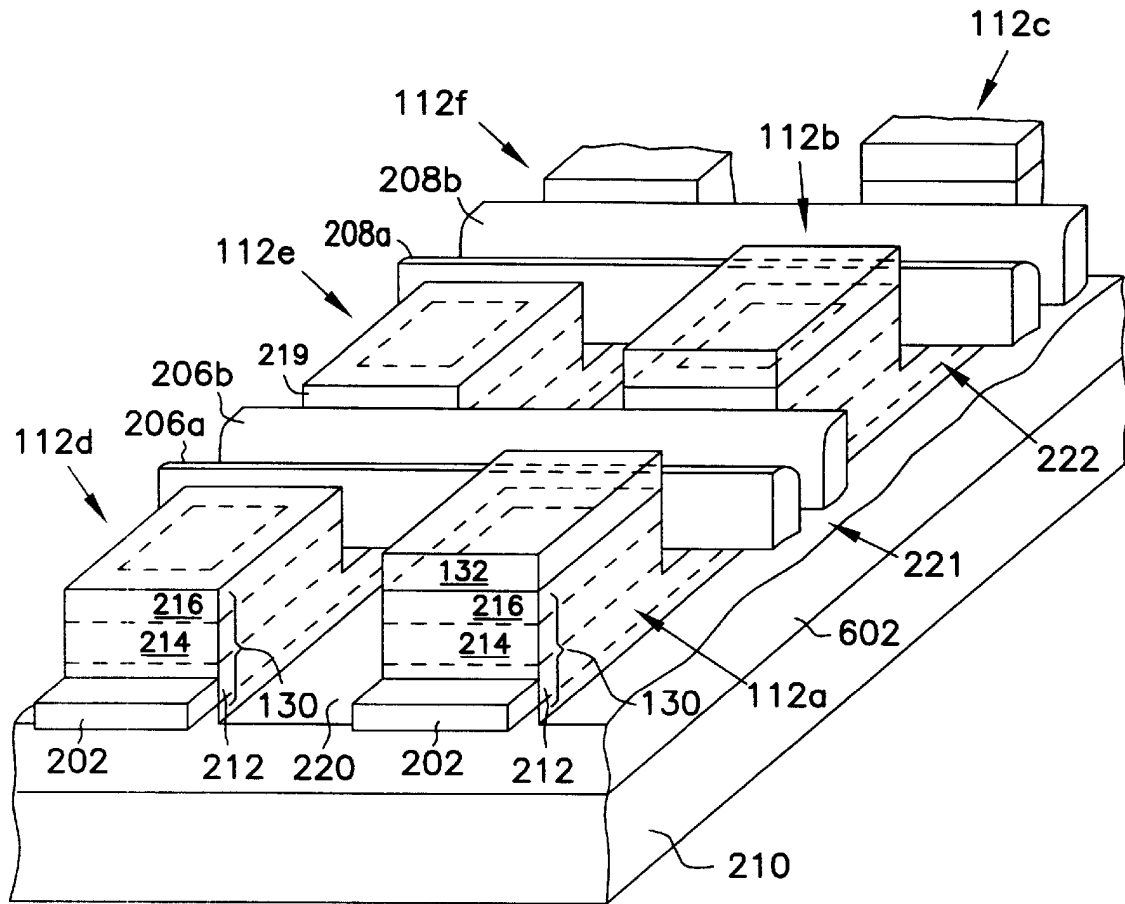

FIG. 8

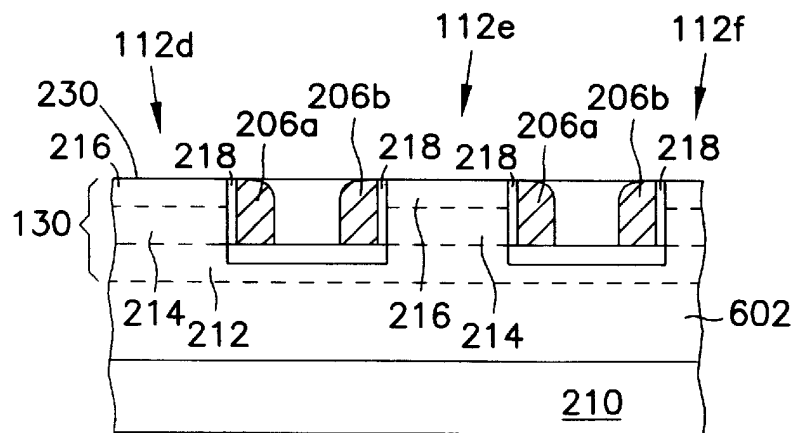

FIG. 10

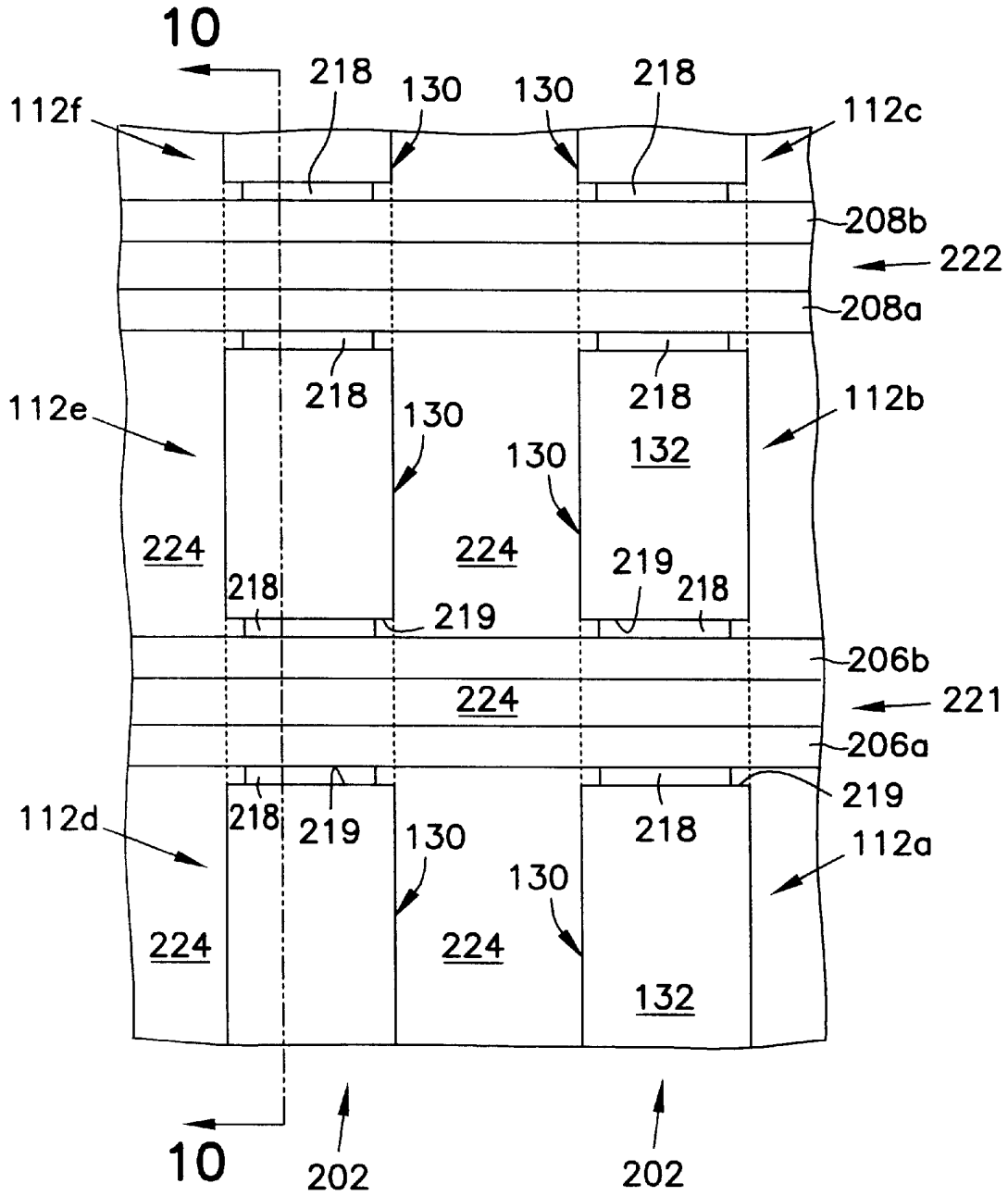

FIG. 9

MEMORY CELL HAVING A VERTICAL TRANSISTOR WITH BURIED SOURCE/ DRAIN AND DUAL GATES

FIELD OF THE INVENTION

The present invention relates generally to integrated circuits, and particularly, but not by way of limitation, to a dynamic random access memory (DRAM) having a memory cell with a vertical access transistor with buried dual gates, and having buried bit and word lines.

BACKGROUND OF THE INVENTION

Semiconductor memories, such as dynamic random access memories (DRAMs), are widely used in computer systems for storing data. A DRAM memory cell typically includes an access field-effect transistor (FET) and a storage capacitor. The access FET allows the transfer of data charges to and from the storage capacitor during reading and writing operations. The data charges on the storage capacitor are periodically refreshed during a refresh operation.

Memory density is typically limited by a minimum lithographic feature size (F) that is imposed by lithographic processes used during fabrication. For example, the present generation of high density dynamic random access memories (DRAMs), which are capable of storing 256 Megabits of data, require an area of $8F^2$ per bit of data. There is a need in the art to provide even higher density memories in order to further increase data storage capacity and reduce manufacturing costs. Increasing the data storage capacity of semiconductor memories requires a reduction in the size of the access FET and storage capacitor of each memory cell. However, other factors, such as subthreshold leakage currents and alpha-particle induced soft errors, require that larger storage capacitors be used. Thus, there is a need in the art to increase memory density while allowing the use of storage capacitors that provide sufficient immunity to leakage currents and soft errors. There is also a need in the broader integrated circuit art for dense structures and fabrication techniques.

SUMMARY OF THE INVENTION

The present invention provides an integrated circuit including a pillar of semiconductor material that extends outwardly from a working surface of a substrate. The pillar has a number of sides. A transistor is formed having a body region and first and second source/drain regions within the pillar. The transistor includes first and second gates that are each associated with a side of the pillar.

The invention also provides a memory device including an array of memory cells. Each cell includes a transistor. Each transistor includes a semiconductor pillar forming body and first and second source/drain regions. The transistor also includes first and second gates disposed adjacent to opposing sides of the pillar. The memory device also includes a plurality of substantially parallel first word lines. Each first word line is disposed orthogonally to the bit lines in a trench between columns of the memory cells. Each first word line allows addressing of first gates of the transistors of the memory cells that are adjacent to the trench in which the first word line is disposed. The memory device also includes a plurality of substantially parallel second word lines. The second word lines are interdigitated with the first word lines. Each second word line is disposed orthogonally to the bit lines in a trench between columns of the memory cells. Each second word line allows addressing of second

gates of the transistors of the memory cells that are adjacent to the trench in which the second word line is disposed. A plurality of bit lines is provided, proximal to the substrate. The bit lines interconnect ones of the first source/drain regions of ones of the memory cells. In one embodiment, the pillars extend outwardly from an insulating portion of the substrate. In another embodiment, the pillars extend outwardly from a semiconductor portion of the substrate.

The invention also provides a method of fabricating an integrated circuit. According to one embodiment of the method, a substrate is provided, and a plurality of bit lines are formed on the substrate. A plurality of access transistors are formed on each of the bit lines. Each access transistor includes a first source/drain region shared by at least a portion of the bit line. Each access transistor also includes a body region and second source/drain region formed vertically on the first source/drain region. A plurality of isolation trenches are formed in the substrate, orthogonal to the bit lines. Each trench is located between access transistors on the orthogonal bit lines. A first word line is formed in a first one of the trenches. The first word line controls conduction between first and second source/drain regions of access transistors that are adjacent to a first side of the first trench. A second word line is formed in a second one of the trenches. The second word line controls conduction between first and second source/drain regions of access transistors that are adjacent to a first side of the second trench.

In one embodiment, the first word line also controls conduction between first and second source/drain regions of access transistors that are adjacent to a second side of the first trench. In another embodiment, the second word line also controls conduction between first and second source/drain regions of access transistors that are adjacent to a second side of the second trench.

In a further embodiment, another first word line is formed in the first trench, for controlling conduction between first and second source/drain regions of access transistors that are adjacent to a second side of the first trench. In yet a further embodiment, a second word line is formed in the second trench, for controlling conduction between first and second source/drain regions of access transistors that are adjacent to a second side of the second trench.

Thus, the invention provides high density integrated circuit structures and fabrication methods, such as for DRAM memory cell arrays and other semiconductor devices. Each memory cell can be fabricated in a surface area that is approximately $4F^2$, where F is a minimum lithographic feature size. In one embodiment, a common first word line is shared by all of the access FETs that are located along both sides of the trench in which the first word line is located. In another embodiment, a common second word line is shared by all of the access FETs that are located along both sides of the trench in which the second word line is located. In further embodiments, split word lines are provided in either or both trenches. The split word lines provide separate addressing of gate regions of access FETs on opposite sides of the trench. Each of the unitary and split word line embodiments can be fabricated on a bulk semiconductor substrate, or on a semiconductor-on-insulator (SOI) substrate that results from using an SOI starting material, or by forming SOI regions during fabrication. The SOI embodiments provide greater immunity to alpha-particle induced soft errors, allowing the use of smaller storage capacitors.

BRIEF DESCRIPTION OF THE DRAWINGS

In the drawings, like numerals describe substantially similar components throughout the several views.

FIG. 1 is a schematic representation illustrating generally one embodiment of a semiconductor memory according to the invention.

FIG. 2 is a perspective view illustrating generally one embodiment of a portion of a memory according to the present invention.

FIG. 3 is a plan view illustrating generally memory cells according to one embodiment of the invention as viewed from above the structures formed on the substrate.

FIG. 4 is a cross-sectional view taken along the cut line 4—4 of FIG. 3.

FIGS. 5A–K describe generally various processing techniques of one embodiment of a method of fabricating memory cells according to the invention.

FIG. 6 is a perspective view illustrating generally another embodiment of a portion of a memory according to the present invention having a semiconductor-on-insulator (SOI) substrate.

FIGS. 7A–C illustrate generally, by way of example, additional steps used to form SOI bars according to one embodiment of the invention.

FIG. 8 is a perspective view illustrating generally another embodiment of a portion of a memory according to the present invention in which split gates are formed.

FIG. 9 is a plan view illustrating generally memory cells according to a split gate embodiment of the invention as viewed from above the structures formed on the substrate.

FIG. 10 is a cross-sectional view taken along the cut line 10—10 of FIG. 9.

FIG. 11 is a perspective view illustrating generally another embodiment of a portion of a memory according to the present invention including split gates and a bulk semiconductor substrate.

FIG. 12 is a cross-sectional view taken along the cut line 12—12 of FIG. 11.

DESCRIPTION OF THE PREFERRED EMBODIMENTS

In the following detailed description of the invention, reference is made to the accompanying drawings which form a part hereof, and in which is shown, by way of illustration, specific embodiments in which the invention may be practiced. The embodiments are intended to describe aspects of the invention in sufficient detail to enable those skilled in the art to practice the invention. Other embodiments may be utilized and changes may be made without departing from the scope of the present invention. In the following description, the terms wafer and substrate are interchangeably used to refer generally to any structure on which integrated circuits are formed, and also to such structures during various stages of integrated circuit fabrication. Both terms include doped and undoped semiconductors, epitaxial layers of a semiconductor on a supporting semiconductor or insulating material, combinations of such layers, as well as other such structures that are known in the art. The following detailed description is not to be taken in a limiting sense, and the scope of the present invention is defined only by the appended claims.

FIG. 1 is a schematic representation illustrating generally one embodiment of an integrated circuit 100, such as a semiconductor memory device, incorporating an array of memory cells provided by the invention. In FIG. 1, circuit 100 illustrates, by way of example but not by way of limitation, a dynamic random access memory (DRAM), but the invention also comprises other integrated circuits includ-

ing any other semiconductor memory devices. In this exemplary embodiment, circuit 100 includes memory cell arrays 110, such as 110A and 110B. Each array 110 includes M rows and N columns of memory cells 112.

In the exemplary embodiment of FIG. 1, each memory cell includes a transfer device, such as n-channel cell access field-effect transistor (FET) 130 or any other transistor or switching device having more than one control terminal inputs. More particularly, access FET 130 includes first and second gate terminals for controlling conduction between its first and second source/drain terminals.

Access FET 130 is coupled at a second source/drain terminal to a storage node of a storage capacitor 132. The other terminal of storage capacitor 132 is coupled to a reference voltage such as a ground voltage VSS. Each of the M rows includes one of word lines WL0, WL1 . . . WLM-1, WLM coupled to the first gate terminals of access FETs 130 or to one of the control terminals of an equivalent switching device. Each of the M rows also includes one of word lines R1, R2, . . . , Rm-1, Rm coupled to the second gate terminals of access FETs 130 in memory cells 112. Thus, the term “word line” includes any interconnection line between gate terminals of access FETs 130, or the control terminals of equivalent switching devices. Each of the N columns includes one of bit lines BL0, BL1 . . . BLN-1, BLN.

Bit lines BL0–BLN are used to write to and read data from memory cells 112. Word lines WL0–WLM and R1–Rm are used to activate access FETs 130 to access a particular row of memory cells 112 that is to be written or read. Addressing circuitry is also included. For example, address buffer 114 controls column decoders 118, which also include sense amplifiers and input/output circuitry that is coupled to bit lines BL0–BLN. Address buffer 114 also controls row decoders 116. Row decoders 116 and column decoders 118 selectably access memory cells 112 in response to address signals that are provided on address lines 120 during read and write operations. The address signals are typically provided by an external controller such as a microprocessor or other memory controller. Each of memory cells 112 has a substantially identical structure, and accordingly, only one memory cell 112 structure is described herein.

In one example mode of operation, circuit 100 receives an address of a particular memory cell 112 at address buffer 114. Address buffer 114 identifies one of the word lines WL0–WLM of the particular memory cell 112 to row decoder 116. Row decoder 116 selectively activates the particular word line WL0–WLM to activate access FETs 130 of each memory cell 112 that is connected to the selected word line WL0–WLM. Column decoder 118 selects the one of bit lines BL0–BLN of the particularly addressed memory cell 112. For a write operation, data received by input/output circuitry is coupled to the one of bit lines BL0–BLN and through the access FET 130 to charge or discharge the storage capacitor 132 of the selected memory cell 112 to represent binary data. For a read operation, data stored in the selected memory cell 112, as represented by the charge on its storage capacitor 132, is coupled to the one of bit lines BL0–BLN, amplified, and a corresponding voltage level is provided to the input/output circuits.

According to one aspect of the invention, each of the first and second gates of access FET 130 is capable of controlling the conduction between its first and second source/drain terminals, as described below. In this embodiment, parallel switching functionality can be effected between the first and second source/drain terminals of access FET 130 by independently operating the particular ones of word lines

WL0–WLn and corresponding ones of word lines R0–Rm. For example, by independently activating word line WL0 and word line R0, both of which are coupled to the same row of memory cells 112, independently controlled inversion channels can be formed in each corresponding access FET 130 by respective first and second gates for allowing conduction between the first and second source/drain regions.

According to another aspect of the invention, each of the first and second gates of access FET 130 is capable of controlling the conduction between its first and second source/drain terminals, but the first and second gates of particular access FETs 130 are synchronously activated, rather than independently operated. For example, by synchronously activating word line WL0 and word line R0, both of which are coupled to the same row of memory cells 112, synchronously activated inversion channels can be formed in each corresponding access FET 130 by respective first and second gates for allowing conduction between the first and second source/drain regions.

In this embodiment, synchronous activation and deactivation of the first and second gates allows better control over the potential distributions in the access FET 130 when it is in a conductive state. Synchronous activation and deactivation can be used to obtain well-controlled fully depleted operating characteristics of access FET 130.

In a further embodiment in which the first and second gates are either synchronously or independently activated, different activation voltages can be applied to the first and second gates of the access FET 130. For example, different voltages can be provided to synchronously activated word lines WL0 and R0, thereby providing different activation voltages to the first and second gates of the access FET 130 to obtain particular desired operating characteristics. Similarly, different deactivation voltages can be applied to the first and second gates of the access FET 130. For example, different deactivation voltages can be provided to synchronously deactivated word lines WL0 and R0 and corresponding first and second gates of access FETs 130, in order to obtain particular desired operating characteristics. Similarly, different activation and deactivation voltages can be applied to independently operated word lines such as WL0 and R0.

FIG. 2 is a perspective view illustrating generally one embodiment of a portion of a memory according to the present invention. FIG. 2 illustrates portions of six memory cells 112a–f, including portions of vertically oriented access FETs 130 therein. Conductive segments of bit lines 202 represent particular ones of bit lines BL0–BLn. Conductive segments of first word line 206 represents any one of word lines WL0–WLn, which provide integrally formed first gates for access FETs 130 between which the particular first word line 206 is interposed. Conductive segments of second word line 208 represents any one of word lines R0–Rm, which provide integrally formed second gates for access FETs 130 between which the particular second word line 208 is interposed. Thus, word lines WL0–WLn and R0–Rm are alternately disposed (interdigitated) within the array 110. The detailed description of memory cell 112 structure refers only to memory cells 112a–f, bit lines 202, and respective first and second word lines 206 and 208 that are associated with memory cells 112a–f. However, the following description similarly applies to all memory cells 112 and similar conductive lines in array 110.

In FIG. 2, vertically oriented access FETs 130 are formed in semiconductor pillars that extend outwardly from an underlying substrate 210. As described below, substrate 210

includes bulk semiconductor starting material, semiconductor-on-insulator (SOI) starting material, or SOI material that is formed from a bulk semiconductor starting material during processing.

In one example embodiment, using bulk silicon processing techniques, access FETs 130 include an n+ silicon layer formed on a bulk silicon substrate 210 to produce first source/drain regions 212 of access FETs 130 and integrally formed n++ conductively doped bit lines 202 defining a particular column of memory cells 112. A p- silicon layer is formed on n+ first source/drain region 212 to form the body region 214 of access FET 130, in which inversion channels may be capacitively generated at the sidewalls of the semiconductor pillar under the control of the first and second gates. A further n+ silicon layer is formed on p- body region 214 to produce second source/drain region 216 of access FET 130. Storage capacitors 132 are formed on the second/source drain regions 216.

Word lines WL0–WLn and R0–Rm are alternately disposed (interdigitated) within the array 110. For example, first word line 206 is interposed between semiconductor pillars of memory cell pairs 112a–b and 112d–e. Second word line 208 is interposed between semiconductor pillars of memory cell pairs 112b–c and 112e–f. Thus, as seen from FIG. 2, access FETs 130 are formed on bit lines 202 in semiconductor pillars extending outwardly from substrate 210 and including body regions 214, and first and second source drain regions 212 and 216, respectively. In this embodiment, bit lines 202 contact bulk semiconductor substrate 210.

Isolation trenches provide isolation between access FETs 130 of adjacent memory cells 112. Columns of memory cells 112 are separated by a trench 220 that is subsequently filled with a suitable insulating material such as silicon dioxide. For example, trench 220 provides isolation between memory cells 112a and 112d and between memory cells 112b and 112e. Rows of memory cells 112 are alternately separated by a trench 221 and 222, each of which are separated from substrate 210 by an underlying insulating layer, described below, and separated from the body region 214 of access FETs 130 by a gate oxide, also described below. For example, trench 221 provides isolation between memory cells 112a and 112b and between memory cells 112d and 112e. In addition, trench 222 provides isolation between memory cells 112b and 112c and memory cells 112e and 112f. Trenches 221 and 222 extend substantially orthogonal to bit lines 202.

FIG. 3 is a plan view illustrating generally memory cells 112a–f as viewed from above the structures formed on substrate 210. FIG. 3 illustrates subsequently formed insulator such as oxide 224, formed in trenches 220 to provide isolation between memory cells 112. In this embodiment, first word line 206 is shared between first gates of access FETs 130 of memory cells 112 in adjacent rows, such as between memory cells 112a–b and 112d–e. First word line 206 is also shared between first gates of other access FETs 130 that are in the same adjacent rows, but coupled to different bit lines 202. First word line 206 is located in trench 221 that extends between the semiconductor pillars of memory cells 112a and 112b. First word line 206 is separated by gate oxide 218 from the vertical sidewalls 219 of the semiconductor pillars on each side of trench 221.

Second word line 208 is shared between second gates of access FETs 130 of memory cells 112 in adjacent rows, such as between memory cells 112b–c and 112e–f. Second word line 208 is also shared between second gates of other access

FETs **130** that are in the same adjacent rows, but coupled to different bit lines **202**. Second word line **208** is located in trench **222** that extends between the semiconductor pillars of memory cells **112b** and **112c**. Second word line **208** is separated by gate oxide **218** from the vertical sidewalls **223** of the semiconductor pillars on each side of trench **222**.

FIG. 4 is a cross-sectional view taken along the cut line 4—4 of FIG. 3. In FIG. 4, respective first and second word lines **206** and **208** are buried below the active semiconductor surface **230** of the semiconductor pillar in the memory cells **112**. Active semiconductor surface **230** represents an upper semiconductor portion of second source/drain region **216**. First and second word lines **206** and **208**, respectively, are isolated from adjacent semiconductor pillars by gate oxide **218**. First and second word lines **206** and **208**, respectively provide integrally formed first and second gate portions that are capacitively coupled to adjacent access FET **130** body regions **214**, such as for forming inversion channel regions therein. In one embodiment, respective first and second word lines **206** and **208** are formed of a refractory metal, such as tungsten or titanium. In another embodiment, first and second word lines **206** and **208** can be formed of n-doped polysilicon. Similarly, other suitable conductors could also be used for first and second words lines **206** and **208**, respectively.

Burying first and second word lines **206** and **208** below semiconductor surface **230** provides additional space on the upper portion of memory cell **112** for formation of storage capacitors **132**. Increasing the area available for forming storage capacitor **132** increases the possible obtainable capacitance value of storage capacitor **132**. In one embodiment, storage capacitor **132** is a stacked capacitor that is formed using any of the many capacitor structures and process sequences known in the art. Other techniques could also be used for implementing storage capacitor **132**. Contacts to the first and second word lines **206** and **208**, respectively, can be made outside of the memory array **110**.

As illustrated in the plan view of FIG. 3, respective first and second word lines **206** and **208** are shared between adjacent memory cells **112**. As a result, only one-half the surface line width of each is allocated to each memory cell. The row pitch of each cell, measured from the centerline of first word line **206** to the centerline of second word line **208**, can be approximately 2F, where F is a minimum lithographic feature size. F corresponds to the length and width presented by the surface of a minimum-sized semiconductor pillar in each memory cell **112**. The column pitch of each cell, measured between centerlines of bit lines **202** can be approximately 2F. Thus, the surface area of each memory cell **112** can be approximately 4F².

FIGS. 5A–K describe generally various processing techniques of one embodiment of a method of fabricating memory cells **112**, such as shown in FIGS. 2–4, using bulk silicon processing techniques. In the embodiment of FIG. 5A, a p-bulk silicon substrate **210** starting material is used. An n++ and n+ silicon composite first source/drain layer **212** is formed on substrate **210**, such as by ion-implantation, epitaxial growth, or a combination of such techniques. The more heavily conductively doped lower portion of the first/source drain layer **212** also functions as the bit line **202**. The thickness of the n++ portion of first source/drain layer **212** is that of the desired bit line **202** thickness, which can be approximately between 0.1 to 0.25 μm . The overall thickness of the first source/drain layer **212** can be approximately between 0.2 to 0.5 μm . A body region layer **214** of p-silicon is formed, such as by epitaxial growth, to a thickness that can be about 0.4 μm . A second source/drain

region layer **216** of n+ silicon is formed, such as by ion-implantation into body region layer **214** or by epitaxial growth on body region layer **214**, to a thickness that can be approximately between 0.2 and 0.5 μm .

In FIG. 5B, an SiO₂ thin pad oxide layer **512** is formed on second source/drain region **216**, such as by chemical vapor deposition (CVD). In one embodiment, pad oxide layer **512** can be approximately 10 nm in thickness. A thin silicon nitride (Si₃N₄) layer **514** is formed on pad oxide layer **512**, such as by CVD. In one embodiment, nitride layer **514** of can be approximately 100 nm in thickness.

In FIG. 5C, photoresist is applied and selectively exposed to provide a mask for the directional etching of trenches **220**, such as by reactive ion etching (RIE). The directional etching results in a plurality of column bars **516** containing the stack of nitride layer **514**, pad oxide layer **512**, second source/drain layer **216**, body region layer **214**, and first source/drain layer **212**. Trenches **220** are etched to a depth that is sufficient to reach the surface **518** of substrate **210**, thereby providing separation between conductively doped bit lines **202**. Bars **516** are oriented in the direction of bit lines **202**. In one embodiment, bars **516** have a surface line width of approximately one micron or less. The depth and width of each trench **220** can be approximately equal to the line width of bars **516**.

In FIG. 5D, the photoresist is removed. Isolation material **224**, such as SiO₂ is deposited to fill the trenches **220**. The working surface is then planarized, such as by chemical mechanical polishing/planarization (CMP).

FIG. 5E illustrates the view of FIG. 5D after clockwise rotation by ninety degrees. In FIG. 5E, a photoresist material is applied and selectively exposed to provide a mask for the directional etching of trenches **221** and **222**, such as by reactive ion etching (RIE) of a plurality of row bars **532** that are disposed orthogonally to bit lines **202**. Forming trenches **221** and **222** includes etching through stacked layers in the portions of bars **516**. Forming trenches **221** and **222** also includes etching through the isolation material **224** disposed between bars **516**.

More particularly, trenches **221** and **222** are etched through nitride layer **514**, pad oxide layer **512**, second source/drain layer **216**, body region layer **214**, and partially into first source/drain layer **212**. Trenches **221** and **222** are etched into bars **516** to a depth of about 100 nm into first source/drain layer **212**, leaving intact an underlying bit line **202** portion of the first source/drain layer **212**. Trenches **221** and **222** are also etched into the isolation material **224** between bars **516**. In one embodiment, after etching nitride layer **514** of bars **516**, a nonselective dry etch is used to remove the isolation material **224** between bars **516** and also the pad oxide layer **512**, second source/drain layer **216**, body region layer **214**, and a portion of first source/drain layer **212** of bars **516**. The directional etching of trenches **221** and **222** results in the formation of a plurality of row bars **532** that are orthogonal to column bars **516**.

FIG. 5F is a plan view illustrating generally the arrangement of parallel bars **516**, and trenches **220** interposed therebetween. Bars **532** are arranged orthogonally to bars **516**. Trenches **221** and **222** are interposed between ones of bars **532**. The resulting semiconductor pillars in the intersecting portions of bars **532** and **516** provide first and second source drain regions **212** and **216**, respectively, and body region **214** for access FETs **130** of memory cells **112**.

In FIG. 5G, which is oriented similarly to FIG. 5E, a conformal silicon nitride layer **540** is formed, such as by CVD. Nitride layer **540** is directionally etched, such as by

RIE, to leave resulting portions of nitride layer **540** only on sidewalls **219** of the bars **532** in trenches **221** and **222**. In one embodiment, the thickness of nitride layer **540** is about 20 nm. An oxide layer **542** is formed, such as by thermal growth, at the base portions of trenches **221** and **222**. Oxide layer **542** insulates the underlying bit lines **202** from structures subsequently formed in trenches **221** and **222**. After forming oxide layer **542**, remaining portions of nitride layer **540** are removed.

In FIG. **5H**, a gate oxide **218** is formed on the exposed sidewalls **219** portions in trenches **221** and **222** of second source/drain region **216**, body region **214**, and first source/drain region **212**. In one embodiment, gate oxide **218** is a high-quality thin oxide layer that is thermally grown on the exposed sidewalls **219** of trenches **221** and **222**.

In FIG. **5I**, a conductive layer **544** is formed over the working surface of the wafer, including filling trenches **221** and **222** in which respective first and second word lines **206** and **208** will be formed. In one embodiment, layer **544** is formed by CVD of a refractory metal, such as tungsten. In another embodiment, layer **544** is formed by CVD of n+ polysilicon.

In FIG. **5J**, CMP or other suitable planarization process is used to remove portions of layer **544** above the interface between pad oxide **512** and second source/drain layer **216**. Pad oxide **512** and nitride layer **514** are also removed during this planarization step. As a result of the planarization step, first and second word lines **206** and **208**, respectively, are formed in respective trenches **221** and **222**.

FIG. **5K** illustrates one embodiment in which, an insulating layer **546**, such as SiO₂, is formed on the working surface of the wafer, such as by CVD. The structure thus formed is then processed to fabricate a storage capacitor **132** on the working surface of the wafer, using known techniques, followed by conventional back end of line (BEOL) procedures.

FIG. **6** is a perspective view illustrating generally another embodiment of a portion of a memory according to the present invention, similar to that described with respect to FIG. **2**. FIG. **6**, however, illustrates an embodiment of the present invention having a semiconductor-on-insulator (SOI) substrate **210** rather than a bulk semiconductor substrate **210**. In one embodiment, SOI substrate **210** of FIG. **6** is obtained using an SOI starting material. In another embodiment, described below, a bulk semiconductor starting material is used, and an bars of SOI are formed during fabrication of circuit **100**, such that the semiconductor pillars, in which portions of access FETs **130** are formed, extend outwardly from an insulating portion **602** of substrate **210**.

One such method of forming bars of SOI is described in the Noble U.S. patent application Ser. No. 08/745,708 which is assigned to the assignee of the present application and which is herein incorporated by reference. Another such method of forming regions of SOI is described in the Forbes U.S. patent application Ser. No. 08/706,230, which is assigned to the assignee of the present application and which is herein incorporated by reference.

FIGS. **7A–C** illustrate generally, by way of example, additional steps used to form SOI bars during the fabrication steps described above with respect to FIGS. **5A–K**, such that the semiconductor pillars, in which portions of access FETs **130** are formed, extend outwardly from an insulating portion **602** of substrate **210**, resulting in the structure illustrated in FIG. **6**.

In FIG. **7A**, the processing steps described above with respect to FIGS. **5A–C** are carried out, forming trenches **220**

that are etched to a depth that is below the original surface **518** of substrate **210**, such as by approximately greater than or equal to 0.6 μm. A nitride layer **704** is formed, such as by CVD. Nitride layer **704** is directionally etched, such as by RIE, to remove nitride layer **704** from the base regions of trenches **220**. Portions of nitride layer **704** remain on the sidewall of trenches **220** to protect adjacent layers during subsequent etching and oxidation.

In FIG. **7B**, an isotropic chemical etch of silicon is used to partially undercut bars **516**. For example, hydrofluoric acid (HF) or a commercial etchant sold under the trade name CP4 (a mixture of approximately 1 part (46% HF):1 part (CH₃COOH):3 parts (HNO₃)) can be used for the isotropic etchant. In one embodiment, the partial undercutting of bars **516** by isotropic etching is timed to remove a volume of silicon that is sufficient to compensate for a subsequently formed volume of oxide, described below. In general, the subsequent oxidation step produces a volume of oxide that is approximately twice that of the silicon consumed during oxidation.

In FIG. **7C**, substrate **210** is oxidized using a standard semiconductor processing furnace at a temperature of approximately 900 to 1,100 degrees Celsius. A wet oxidizing ambient is used in the furnace chamber to oxidize the exposed silicon regions in the lower portion of trenches **220**. Substrate **210** is oxidized for a time period that is sufficient to form oxide insulating portion **602** that fully undercuts bars **516**. Insulating portion **602** underlies both bars **516** and trenches **220**, and isolates the bit lines **202** and access FETs **130** formed on bit lines **202** from an underlying semiconductor portion of substrate **210**. Nitride layer **704** is removed, and processing then continues as described above with respect to FIGS. **5D–K**, resulting in the structure of FIG. **6**.

In one embodiment, bars **516** are sufficiently narrow such that the oxidation step that undercuts bars **516** produces sufficient oxide to fill trenches **220**, resulting in a generally planar structure. This avoids the need for a separate step of depositing an oxide insulation material **224** described with respect to FIG. **5D**. The oxidation time period depends on the width of bars **516** and the effective width of bars **516** after the undercut etch step. Narrower bars **516** require shorter oxidation times. For example, for sub-0.25 micron technology, oxidation time is approximately 1 hour. In another embodiment, the etch step fully undercuts bars **516** before oxidation. This further reduces oxidation time.

FIGS. **8–10** illustrate generally another embodiment of a portion of a memory according to the present invention, similar to that described with respect to FIG. **6**. In the embodiment of FIGS. **8–10**, however, first and second word lines **206** and **208**, respectively, are each split into separate conductors. First word line **206** is split into independently operable first word lines **206a** and **206b**, each disposed in trench **221** and electrically isolated from each other. Second word line **208** is split into independently operable second word lines **208a** and **208b**, each disposed in trench **222** and electrically isolated from each other, such as by SiO₂. Thus, gate regions need not be shared between access FETs **130** in adjacent memory cells **112** on opposing sides of trenches **221** and **222**. First and second word lines **206** and **208** can be formed of a refractory metal or n+ polysilicon or other suitable conductor, as described above.

In FIGS. **8–10**, for example, first word line **206a** extends in trench **221** adjacent to the vertical sidewalls **219** of the semiconductor pillars of in-line memory cells **112a** and **112d**, separated therefrom by gate oxide **218**. First word line

206b extends in trench **221** adjacent to the vertical sidewalls **219** of the semiconductor pillars of in-line memory cells **112b** and **112e**, separated therefrom by gate oxide **218**. Second word line **208a** extends in trench **222** adjacent to the vertical sidewalls **219** of the semiconductor pillars of in-line memory cells **112b** and **112e**, separated therefrom by gate oxide **218**. Second word line **208b** extends in trench **222** adjacent to the vertical sidewalls **219** of the semiconductor pillars of in-line memory cells **112c** and **112f**.

Operation of the access FET **130** of memory cell **112b**, for example, includes operation of the first word line **206b** and second word line **208a**, as described above. A positive potential is applied to either or both of first word line **206b** and second word line **208a**, as described above to turn on the access FET **130** of memory cell **112b**. However, since first word line **206b** is not shared by the access FET **130** of memory cell **112a**, subthreshold leakage is not induced in the access FET **130** of memory cell **112a** during activation of first word line **206b** to operate the access FET **130** of memory cell **112b**. Similarly, since second word line **208a** is not shared by the access FET **130** of memory cell **112c**, subthreshold leakage in the access FET **130** of memory cell **112c** is not induced during activation of second word line **208a** to operate the access FET **130** of memory cell **112b**.

The use of split first word lines **206a-b** and split second word lines **208a-b** avoids the problem of sub-threshold conduction in access FETs **130** in one row while the memory cells **112** in the adjacent row are being addressed. Each memory cell **112** is capable of being uniquely addressed by a combination of first word line **206** and second word line **208** voltages. These voltages need not appear on the first word line **206** and second word line **208** of adjacent rows of memory cells **112**.

The structures of FIGS. **8-10** can be fabricated by process steps similar to those described with respect to FIGS. **5A-C** forming bars **516** separated by trenches **220**. This is followed by the process steps described with respect to FIGS. **7A-C** follow, isolating bars **516** from an underlying semiconductor portion of substrate **210** by insulating portion **602**. This is followed by the process steps described with respect to FIGS. **5D-J** forming a planar structure including a unitary conductor first word line **206** in first trench **221** and a unitary conductor second word line **208** in second trench **222**.

Unitary conductor first word line **206** thus formed is split to form separate conductors **206a-b**. A refractory metal, n+ polysilicon, or other conductor is deposited as a conformal film that can have a thickness of less than or equal to approximately $F/3$, where F is the minimum feature size. The conformal film is then directionally etched, thereby leaving resulting split conductor word lines **206a-b** adjacent to the vertical sidewall **219**, separated therefrom by gate oxide **218**. Second word line **208** can be similarly split into separate conductors **208a-b** during the same deposition and directional etch steps. Splitting unitary conductor first and second word lines **206** and **208**, respectively, provides the resulting structures illustrated in FIGS. **8-10**, but is not required to practice the invention. These steps can be omitted, such as to obtain the structures illustrated in FIGS. **2-4**.

FIGS. **11-12** illustrate generally another embodiment of a portion of a memory according to the present invention, similar to that described with respect to FIGS. **8-10**, but fabricating using a bulk silicon substrate **210**, as described with respect to FIGS. **2-4**. The structures of FIGS. **11-12** are fabricated by process steps similar to those described with respect to FIGS. **5A-C**, forming bars **516** separated by

trenches **220**. The process steps described with respect to FIGS. **7A-C** follow are omitted from this embodiment. Instead, this is followed by the process steps described with respect to FIGS. **5D-J** forming a planar structure including a unitary conductor first word line **206** in first trench **221** and a unitary conductor second word line **208** in second trench **222**. The unitary conductor first and second word lines **206** and **208**, respectively, are then split as described above with respect to FIGS. **8-10**.

The above structures and fabrication methods have been described, by way of example, and not by way of limitation, with respect to memory integrated circuits such as dynamic random access memories (DRAMs). However, the scope of the invention includes any other integrated circuit applications in which the above structures and fabrication methods are used.

Thus, it has been shown that the invention provides integrated circuit structures and fabrication methods, such as for DRAM memory cell arrays and other semiconductor devices. Each memory cell includes a vertical access FET, formed on a bit line, and first and second gates integrally formed with respective first and second word lines that are buried in trenches that extend along opposite sides of the memory cell. Each memory cell can be fabricated in a surface area that is approximately $4F^2$, where F is a minimum lithographic feature size. In one embodiment, a common first word line is shared by all of the access FETs that are located along both sides of the trench in which the first word line is located. Also, a common second word line is shared by all of the access FETs that are located along both sides of the trench in which the second word line is located. In another embodiment, split word lines are provided in each trench, and the two split word lines provide separate addressing of gate regions of access FETs on opposite sides of the trench. Each of the unitary and split word line embodiments can be fabricated on a bulk semiconductor substrate, or on a semiconductor-on-insulator (SOI) substrate that results from using an SOI starting material, or by forming SOI regions during fabrication.

What is claimed is:

1. An integrated circuit, comprising:

a pillar of semiconductor material that extends outwardly from a working surface of a substrate, the pillar having a number of sides;

a transistor having a body region and first and second source/drain regions formed within the pillar, and having first and second gates that are each associated with a side of the pillar; and

an interconnect line formed of monocrystalline semiconductor material and disposed below the body region for interconnecting with first source/drain regions of adjacent transistors of the integrated circuit.

2. The integrated circuit of claim 1, further comprising a storage capacitor coupled to the second source/drain diffusion.

3. The integrated circuit of claim 1, wherein the first source/drain region includes a more heavily doped bit line portion.

4. The integrated circuit of claim 1, wherein the pillar extends outwardly from an insulating portion of the substrate.

5. The integrated circuit of claim 1, wherein the pillar extends outwardly from a semiconductor portion of the substrate.

6. A memory device, comprising:

an array of memory cells, each cell comprising a transistor including a semiconductor pillar forming body and first

13

- and second source/drain regions, and first and second gates disposed adjacent to opposing sides of the pillar;
- a plurality of substantially parallel first word lines, each first word line disposed orthogonally to the bit lines in a trench between columns of the memory cells for addressing of first gates of the transistors of the memory cells that are adjacent to the trench in which the first word line is disposed;
- a plurality of substantially parallel second word lines, interdigitated with the first word lines, each second word line disposed orthogonally to the bit lines in a trench between columns of the memory cells for allowing addressing of second gates of the transistors of the memory cells that are adjacent to the trench in which the second word line is disposed; and
- a plurality of buried bit lines, disposed below the body region, and interconnecting ones of the first source/drain regions of ones of the memory cells.
7. The memory device of claim 6, wherein each memory cell further comprises a storage capacitor coupled to the second source/drain diffusion.
8. The memory device of claim 6, wherein the pillars extend outwardly from an insulating portion of the substrate.
9. The memory device of claim 6, wherein the pillars extend outwardly from a semiconductor portion of the substrate.
10. The memory device of claim 6, wherein the integrated circuit surface area of the memory cell is $4F^2$, where F is a minimum feature size.
11. An integrated circuit, comprising:
- a pillar of semiconductor material that extends outwardly from a working surface of a substrate, the pillar having an upper surface and a number of sides;
- a transistor having a vertically stacked body and first and second source/drain regions formed within the pillar, and having first and second gates that are each associated with a side of the pillar, wherein the first and second gates are located below the upper surface of the semiconductor pillar; and
- an interconnect line formed of monocrystalline semiconductor material and disposed below the body region for interconnecting with first source/drain regions of adjacent transistors of the integrated circuit.
12. The integrated circuit of claim 11, wherein the first and second gates are associated with opposite sides of the pillar.
13. The integrated circuit of claim 11, including an insulating layer between the first source/drain region and an underlying semiconductor portion of the substrate.
14. A memory array comprising:
- a plurality of substantially parallel bit lines at least partially on a substrate;
- a plurality of memory cells, each memory cell including an access transistor having body and first and second source/drain regions vertically formed on one of the bit lines, the second source/drain region including an upper semiconductor surface and the bit lines disposed below the body region;
- a plurality of first and second word lines, the first and second word lines interdigitated with each other and disposed orthogonally to the bit lines in isolation trenches, wherein the bit lines and the first and second

14

- word lines are located below the upper semiconductor surface of the second source/drain region; and
- a plurality of isolation trenches extending parallel to and between the bit lines, and interposed between ones of the access transistors.
15. The memory array of claim 14, wherein the bit lines include portions of the first source/drain regions of ones of the access transistors.
16. The memory array of claim 14, wherein the first word line provides common first gate regions for access transistors on opposing sides of the trench in which the first word line is disposed.
17. The memory array of claim 14, wherein the second word line provides common second gate regions for access transistors on opposing sides of the trench in which the second word line is disposed.
18. The memory array of claim 14, wherein the first word line provides separate conductors for first gate regions of access transistors on opposite sides of the trench in which the first word line is disposed.
19. The memory array of claim 14, wherein the second word line provides separate conductors for second gate regions of access transistors on opposite sides of the trench in which the second word line is disposed.
20. The memory array of claim 14, including an insulating layer interposed between the bit lines and a semiconductor portion of the substrate.
21. A memory array comprising:
- a plurality of substantially parallel bit lines at least partially on a substrate;
- a plurality of memory cells, each memory cell including an access transistor having body and first and second source/drain regions vertically formed on one of the bit lines such that the body region is located above the bit line, the second source/drain region including an upper semiconductor surface;
- a plurality of first word line pairs, each first word line pair disposed in first trenches extending orthogonal to the bit lines, each first word line in the first word line pair separated from the other first word line in the first word line pair;
- a plurality of second word line pairs, each second word line pair disposed in second trenches that are interdigitated with the first trenches, wherein the second trenches extend orthogonal to the bit lines, each second word line in the second word line pair separated from the other second word line in the second word line pair; and
- a plurality of isolation trenches extending parallel to and between the bit lines, and interposed between ones of the access transistors.
22. The memory array of claim 21, wherein the bit lines and the first and second word line pairs are located below the upper semiconductor surface of the second source/drain region.
23. The memory array of claim 21, including an insulating layer interposed between the bit lines and a semiconductor portion of the substrate.
24. The memory array of claim 21, wherein the bit lines include at least a portion of ones of the first source/drain regions.