



US006246606B1

(12) **United States Patent**  
**Forbes et al.**

(10) **Patent No.:** **US 6,246,606 B1**  
(45) **Date of Patent:** **\*Jun. 12, 2001**

(54) **MEMORY USING INSULATOR TRAPS**

(75) Inventors: **Leonard Forbes**, Corvallis, OR (US);  
**Joseph E. Geusic**, Berkeley Heights,  
NJ (US)

(73) Assignee: **Micron Technology, Inc.**, Boise, ID  
(US)

(\*) Notice: This patent issued on a continued prosecution application filed under 37 CFR 1.53(d), and is subject to the twenty year patent term provisions of 35 U.S.C. 154(a)(2).

Subject to any disclaimer, the term of this patent is extended or adjusted under 35 U.S.C. 154(b) by 0 days.

(21) Appl. No.: **09/388,656**

(22) Filed: **Sep. 2, 1999**

**Related U.S. Application Data**

(62) Division of application No. 08/969,099, filed on Nov. 13, 1997.

(51) **Int. Cl.<sup>7</sup>** ..... **G11C 16/00**

(52) **U.S. Cl.** ..... **365/185.03**; 365/185.98;  
365/825.29

(58) **Field of Search** ..... 365/185.03, 185.01,  
365/185.28, 185.29, 185.19, 94, 103

(56) **References Cited**

**U.S. PATENT DOCUMENTS**

4,507,673	3/1985	Aoyama et al. ....	357/23 R
4,661,833	* 4/1987	Mizutani .....	365/185.01
4,939,559	7/1990	DiMaria et al. ....	357/23.5
5,021,999	6/1991	Kohda et al. ....	365/168
5,027,171	6/1991	Reedy et al. ....	357/23.5
5,111,430	5/1992	Morie .....	365/185
5,253,196	10/1993	Shimabukuro .....	365/45
5,296,560	3/1994	Harari .....	365/185
5,317,535	5/1994	Talreja et al. ....	365/185

5,388,069	2/1995	Kokubo .....	365/185
5,424,993	6/1995	Lee et al. ....	365/218
5,430,670	7/1995	Rosenthal .....	365/45
5,434,815	7/1995	Smarandoiu et al. ....	365/189.01
5,438,544	8/1995	Makino .....	365/185
5,449,941	9/1995	Yamazaki et al. ....	257/411
5,467,306	11/1995	Kaya et al. ....	365/185.2
5,477,485	12/1995	Bergemont et al. ....	365/185.24
5,485,422	1/1996	Bauer et al. ....	365/168
5,493,140	2/1996	Iguchi .....	257/316

(List continued on next page.)

**FOREIGN PATENT DOCUMENTS**

3-222367	10/1991	(JP) .....	H01L/29/784
6-224431	8/1994	(JP) .....	H01L/29/784
6-302828	10/1994	(JP) .....	H01L/29/788
8-255878	10/1996	(JP) .....	H01L/27/10

**OTHER PUBLICATIONS**

Adler, E., et al., "The Evolution of IBM CMOS DRAM Technology", 167-188, (Jan./Mar., 1995).

(List continued on next page.)

*Primary Examiner*—Tan T. Nguyen

(74) *Attorney, Agent, or Firm*—Schwegman, Lundberg, Woessner & Kluth, P.A.

(57) **ABSTRACT**

A memory cell provides point defect trap sites in an insulator for storing data charges. Single electrons are stored on respective point defect trap sites and a resulting parameter, such as transistor drain current, is detected. By adjusting the density of the point defect trap sites, more uniform step changes in drain current are obtained as single electrons are stored on or removed from respective trap sites. By also adjusting the trapping energy of the point defect trap sites, the memory cell provides either volatile data storage, similar to a dynamic random access memory (DRAM), or nonvolatile data storage, similar to an electrically erasable and programmable read only memory (EEPROM). The memory cell is used for storing binary or multi-state data.

**18 Claims, 4 Drawing Sheets**

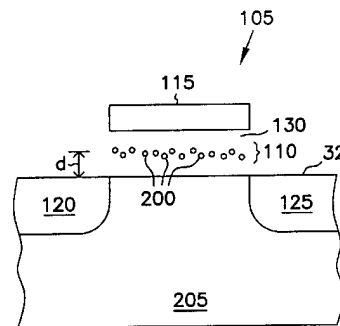
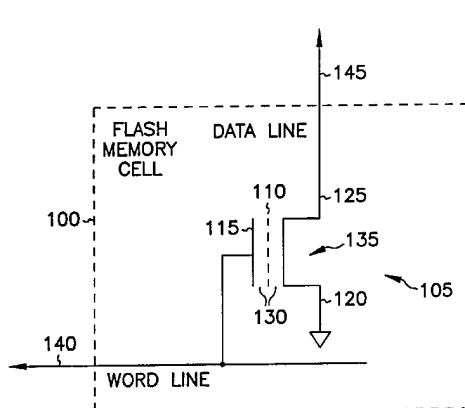

## U.S. PATENT DOCUMENTS

5,508,543	4/1996	Hartstein et al.	257/314
5,627,781	5/1997	Hayashi et al.	365/185.2
5,670,790	9/1997	Katoh et al.	257/14
5,714,766	2/1998	Chen et al.	257/20
5,740,104	4/1998	Forbes	365/185.03
5,754,477	5/1998	Forbes	365/185.33
5,959,896	9/1999	Forbes	365/185.33

## OTHER PUBLICATIONS

- Alok, D., et al., "Electrical Properties of Thermal Oxide Grown on N-type 6H-Silicon Carbide", *Applied Physics Letters*, 64, 2845-2846, (May 23, 1994).
- Boeringer, D.W., et al., "Avalanche amplification of multiple resonant tunneling through parallel silicon microcrystallites", *Physical Rev. B*, 51, 13337-13343, (1995).
- DeKeersmaecker, R., et al., "Electron Trapping and Detrapping Characteristics of Arsenic-Implanted SiO(2) Layers", *J. Appl. Phys.*, 51, 1085-1101, (Feb. 1980).
- Demichelis, F., et al., "Influence of Doping on the Structural and Optoelectronic Properties of Amorphous and Microcrystalline Silicon Carbide", *Journal of Applied Physics*, 72, 1327-1333, (Aug. 15, 1992).
- Demichelis, F., et al., "Physical Properties of Undoped and Doped Microcrystalline SiC:H Deposited By PECVD", Materials Research Society Symposium Proceedings, 219, Anaheim, CA, 413-418, (Apr. 30-May-3, 1991).
- DiMaria, D., et al., "Capture and Emission of Electrons at 2.4-eV-Deep Trap Level in SiO(2) Films", *Physical Review B*, 11, 5023-5030, (Jun. 1975).
- DiMaria, D., et al., "Enhanced Conduction and Minimized Charge Trapping in Electrically Alterable Read-Only Memories Using Off-Stoichiometric Silicon Dioxide Films", *J. Appl. Phys.*, 55, 3000-3019, (Apr. 1984).
- Dipert, B., et al., "Flash Memory Goes Mainstream", *IEEE Spectrum*, 30, 48-52, (1993).
- Edelberg, E., et al., "Visible Luminescence from Nanocrystalline silicon films produced by plasma enhanced chemical vapor deposition", *Appl. Phys. Lett.*, 68, 1415-1417, (1996).
- Forbes, L., et al., "Field Induced Reemission of Electrons Trapped in SiO(2)", *IEEE Trans. on Electron Devices*, ED-26(11), 1816-1818, (Nov. 1979).
- Forbes, L., et al., "Thermal Re-Emission of Trapped Hot Electrons in NMOS Transistors", *IEEE Trans. on Electron Devices*, 38, 2712, (Dec. 1991).
- Hamakawa, Y., et al., "Optoelectronics and Photovoltaic Applications of Microcrystalline SiC", Materials Research Society Symposium Proceedings, 164, Boston, MA, 291-301, (Nov. 29-Dec. 1, 1989).
- Hanafi, H., et al., "Fast and Long Retention-Time Nano-Crystal Memory", *IEEE Trans. on Electron Devices*, 43, 1553-1558, (Sep. 1996).
- Hori, T., et al., "A MOSFET with Si-Implanted Gate-SiO(2) Insulator for Nonvolatile Memory Applications", *Int'l Electron Devices Meeting: Technical Digest*, San Francisco, CA, 469-472, (Dec. 1992).
- Hsu, C., et al., "Observation of Threshold Oxide Electric Field for Trap Generation in Oxide Films on Silicon", *J. Appl. Phys.*, 63, 5882-5884, (Jun. 1988).
- Hu, G., et al., "Will Flash Memory Replace Hard Disk Drive?", *1994 IEEE International Electron Device Meeting*, Panel Discussion, Session 24, Outline, 1 p., (Dec. 13, 1994).
- Huntley, D., et al., "Deep Traps in Quartz and Their Use for Optical Dating", *Canadian J. Physics*, 74, 81-91, (Mar./Apr. 1996).
- Hwang, N., et al., "Tunneling and Thermal Emission of Electrons at Room Temperature and Above from a Distribution of Deep Traps in SiO<sub>2</sub>", Proc. Int'l Elec. Devices and Materials Symp., Taiwan, 559-562, (Nov. 1992).
- Hwang, N., et al., "Tunneling and Thermal Emission of Electrons from a Distribution of Deep Traps in SiO<sub>2</sub>", *IEEE Trans on Electron Devices*, 40(6), 1100-1103, (Jun. 1993).
- Hybertsen, M.S., "Absorption and Emission of Light in Nanoscale Silicon Structures", *Phys. Rev. Lett.*, 72, 1514-1517, (1994).
- Jung, T.S., et al., "A 3.3V, 128Mb Multi-Level NAND Flash Memory for Mass Storage Applications", 1996 IEEE Solid-State Circuits Conf., Digest of Technical Papers, 512, (1996).
- Kalnitsky, A., et al., "Memory Effect and Enhanced Conductivity in Si-Implanted Thermally Grown SiO(2)", *IEEE Trans. on Electron Devices*, ED-34, 2372, (Nov. 1987).
- Kalnitsky, A., et al., "Rechargeable E' Centers in Silicon-Implanted SiO(2) Films", *J. Appl. Phys.*, 67, 7359-7367, (Jun. 1990).
- Kamata, T., et al., "Substrate Current Due to Impact Ionization in MOS-FET", *Japan. J. Appl. Phys.*, 15, 1127-1134, (Jun. 1976).
- Kato, M., et al., "Read-Disturb Degradation Mechanism due to Electron Trapping in the Tunnel Oxide for Low-voltage Flash Memories", *IEEE Electron Device Meeting*, 45-48, (1994).
- Lee, M., et al., "Thermal Self-Limiting Effects in the Long-Term AC Stress on N-Channel LDD MOSFET's", Proc.: 9th Biennial University/Government/Industry Microelectronics Symp., Melbourne, FL, 93-97, (Jun., 1991).
- Ohkawa, M., et al., "A 98 mm 3.3V 64Mb Flash Memory with FN-NOR type 4-Level Cell", IEEE International Solid-State Circuits Conference, 36-37, (1996).
- Prendergast, J., "FLASH or DRAM: Memory Choice for the Future", *IEEE Electron Device Meeting, Session 25*, Phoenix, AZ, (1995).
- Schoenfeld, O., et al., "Formation of Si Quantum dots in Nanocrystalline silicon", Proc. 7th Int. Conf. on Modulated Semiconductor Structures, Madrid, 605-608, (1995).
- Shimabukuro, R.L., et al., "Circuitry for Artificial Neural Networks with Non-volatile Analog Memories", IEEE Int'l Symp. on Circuits and Systems, 2, 1217-1220, (1989).
- Shimabukuro, R.L., et al., "Dual-Polarity Nonvolatile MOS Analogue Memory (MAM) Cell for Neural-Type Circuitry", *Electronics Lett.*, 24, 1231-1232, (Sep. 15, 1988).
- Suh, K.D., et al., "A 3.3 V 32 Mb NAND Flash Memory with Incremental Step Pulse Programming Scheme", *IEEE J. Solid-State Circuits*, 30, 1149-1156, (Nov. 1995).
- Takeuchi, K., et al., "A Double-Level-V Select Gate Array Architecture for Multilevel NAND Flash Memories", *IEEE Journal of Solid-State Circuits*, 31, 602-609, (Apr. 1996).
- Thomas, J., et al., "Electron Trapping Levels in Silicon Dioxide Thermally Grown in Silicon", *J. Physics and Chemistry of Solids*, 33, 2197-2216, (1972).
- Thompson, S., et al., "Positive Charge Generation in SiO(2) by Electron-Impact Emission of Trapped Electrons", *J. Appl. Phys.*, 72, 4683-4695, (Nov. 1992).

- Thompson, S., et al., "Tunneling and Thermal Emission of Electrons from a Distribution of Shallow Traps in SiO<sub>2</sub>", *Appl. Phys. Lett.*, 58, 1262–1264, (Mar. 1991).
- Tiwari, S., et al., "A silicon nanocrystal based memory", *Appl. Physics Lett.*, 68, 1377–1379, (1996).
- Tiwari, S., et al., "Volatile and Non-Volatile Memories in Silicon with Nano-Crystal Storage", *Int'l Electron Devices Meeting: Technical Digest*, Washington, DC, 521–524, (Dec. 1995).
- Tsu, R., et al., "Slow Conductance oscillations in nanoscale silicon clusters of quantum dots", *Appl. Phys. Lett.*, 65, 842–844, (1994).
- Tsu, R., et al., "Tunneling in Nanoscale Silicon Particles Embedded in an SiO<sub>2</sub>/sub/2 Matrix", Abstract, IEEE Device Research Conference, 178–179, (1996).
- Vuillaume, D., et al., "Charging and Discharging Properties of Electron Traps Created by Hot-Carrier Injections in Gate Oxide of N-Channel Metal Oxide Semiconductor Field Effect Transistor", *J. Appl. Phys.*, 73, 2559–2563, (Mar. 1993).
- Ye, Q., et al., "Resonant Tunneling via Microcrystalline silicon quantum confinement", *Physical Rev. B*, 44, 1806–1811, (1991).
- Yih, C.M., et al., "A Consistent Gate and Substrate Current Model for Sub-Micron MOSFET's by Considering Energy Transport", *Int'l Symp. on VLSI Tech., Systems and Applic.*, Taiwan, 127–130, (1995).
- Young, D., et al., "Characterization of Electron Traps in Aluminum-Implanted SiO<sub>2</sub>", *IBM J. Research and Development*, 22, 285–288, (May 1978).
- Zhao, X., et al., "Nanocrystalline Si: a material constructed by Si quantum dots", 1st Int. Conf. on Low Dimensional Structures and Devices, Singapore, 467–471, (1995).
- Wolf, S., In: *Silicon Processing for the VLSI Era*, vol. 1, Lattice Press, Sunset Beach, CA, p. 227, (1990).
- Wolf, S., In: *Silicon Processing for the VLSI Era*, vol. 2, Lattice Press, Sunset Beach, CA, p. 319, (1990).
- Wolf, S., "Ion Implantation for VLSI", *Silicon Processing for the VLSI Era*, vol. 1, 280, (1990).

\* cited by examiner



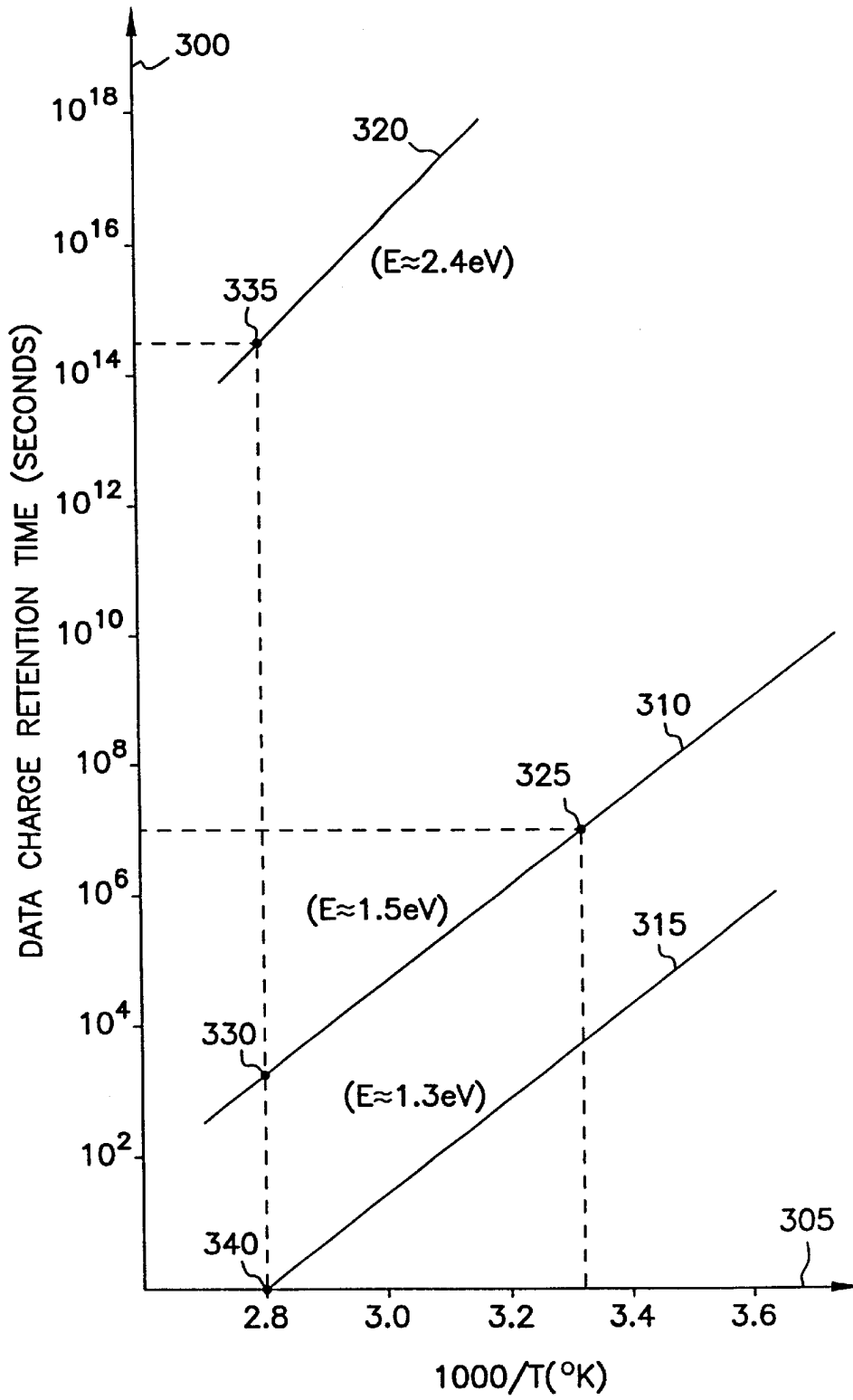

FIG. 3

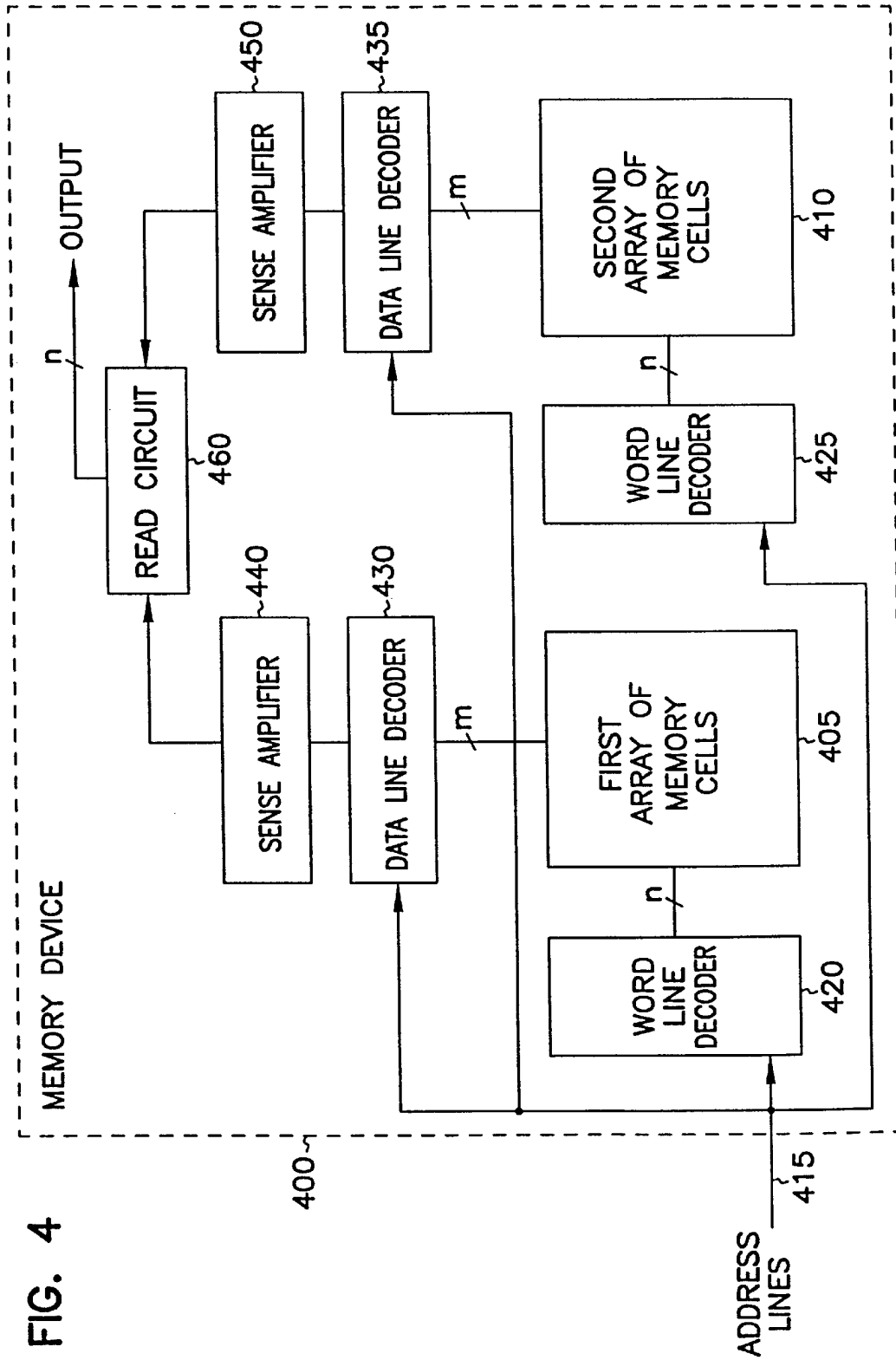

FIG. 4

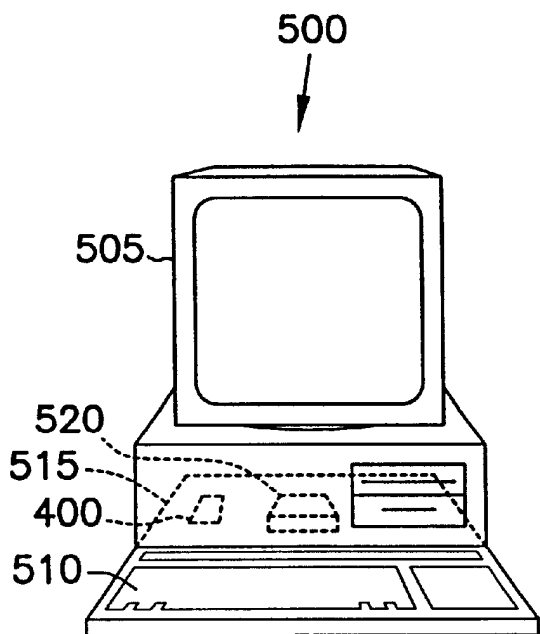

FIG. 5

**MEMORY USING INSULATOR TRAPS****CROSS REFERENCE TO RELATED APPLICATIONS**

This application is a divisional of U.S. Ser. No. 08/969,099 filed Nov. 13, 1997.

This application is related to a co-pending, commonly assigned U.S. patent application of L. Forbes, entitled "A MULTI-STATE FLASH MEMORY CELL AND METHOD FOR PROGRAMMING SINGLE ELECTRON DIFFERENCES," Ser. No. 08/790,903, filed on Jan. 29, 1997, which disclosure is herein incorporated by reference.

**TECHNICAL FIELD OF THE INVENTION**

This invention relates generally to integrated circuits and particularly, but not by way of limitation, to an integrated circuit memory device using insulator traps for storing charge.

**BACKGROUND OF THE INVENTION**

Integrated circuit memory devices provide both volatile and nonvolatile storage of data. One goal in designing such devices is to increase the storage density so that more data can be stored in a memory device that occupies less volume. One technique of increasing storage density is described in a co-pending, commonly assigned U.S. patent application of L. Forbes, entitled "A MULTI-STATE FLASH MEMORY CELL AND METHOD FOR PROGRAMMING SINGLE ELECTRON DIFFERENCES," Ser. No. 08/790,903, filed on Jan. 29, 1997, which disclosure is herein incorporated by reference.

The 08/790,903 U.S. patent application discloses a flash memory cell. The cell includes a transistor with a floating gate that is formed from a number of crystals of semiconductor material. The crystals are disposed in the gate oxide of the transistor. The size of the crystals and their distance from a surface of a semiconductor layer of the transistor are selected such that the crystals can trap a single electron by hot electron injection. Each trapped electron causes a measurable change in the drain current of the transistor. Thus, multiple data bits can be stored and retrieved by counting the changes in the drain current.

One potential shortcoming of the memory cell disclosed in the 08/790,903 U.S. patent application is that it does not necessarily have uniformly sized crystals. Instead, the grains have a finite grain size that may vary between individual grains. As a result, the capacitance of individual grains may also vary between individual grains. Even if such grains are capable of storing only a single electron, the resulting voltage on any particular grain may depend on the grain size. As electrons are being stored on respective grains, the resulting drain current may change in irregularly sized steps, making memory states differing only by a single stored electron difficult to distinguish. For the reasons described above, and for other reasons that will become apparent upon reading the following detailed description of the invention, there is a need for a memory cell that provides more uniformity in the step changes in drain current as single electrons are being stored on the memory cell.

**SUMMARY OF THE INVENTION**

The present invention provides, among other things, a memory cell that provides more uniformity in step changes in drain current as single electrons are being stored on the memory cell. In one embodiment, the invention provides a

memory cell comprising an insulator carrying trap sites at a density such that the trap sites are substantially shielded from each other by intervening portions of the insulator. In another embodiment, the invention provides a memory cell comprising an insulator carrying point defect trap sites that are electrically isolated from each other by intervening portions of the insulator. In a further embodiment, the invention provides a memory cell comprising a transistor, including a source, a drain, a channel region between the source and drain, a control gate, an insulator between the control gate and the channel region, and a floating gate. The floating gate includes point defect trap sites that are carried by the insulator and electrically isolated from each other by intervening portions of the insulator.

Another aspect of the invention provides memory device comprising an array of memory cells. Each memory cell includes a transistor in which a gate insulator carries trap sites at a density such that the trap sites are substantially shielded from each other by intervening portions of the insulator. The memory device also includes addressing circuitry coupled to the array of memory cells for accessing individual memory cells in the array of memory cells, and a read circuit coupled to the memory cell array and reading data from memory cells in the array of memory cells. Another aspect of the invention provides a computer system including the memory device as described above.

Another aspect of the invention provides a method of storing and retrieving data. The method includes altering the number of electrons stored on a memory cell in trap sites carried by an insulator at a density such that the trap sites are substantially shielded from each other by intervening portions of the insulator. A resulting parameter (e.g., current, voltage, or charge) is detected. The resulting parameter is based on the number of electrons stored in the trap sites.

In summary, the memory cell provides point defect trap sites in an insulator for storing data charges. Single electrons are stored on respective point defect trap sites and a resulting parameter, such as transistor drain current, is detected. By adjusting the density of the point defect trap sites, more uniform step changes in drain current are obtained as single electrons are stored on or removed from respective trap sites. By also adjusting the trapping energy of the point defect trap sites, the memory cell provides either volatile data storage, similar to a dynamic random access memory (DRAM), or nonvolatile data storage, similar to an electrically erasable and programmable read only memory (EEPROM). The memory cell is used for storing binary or multi-state data.

**BRIEF DESCRIPTION OF THE DRAWINGS**

In the drawings, like numerals describe substantially similar components throughout the several views.

FIG. 1 is a schematic diagram illustrating generally one embodiment of a memory cell according to one aspect of the present invention.

FIG. 2 is a cross-sectional diagram illustrating generally one embodiment of transistor according to one aspect of the present invention.

FIG. 3 is a graph illustrating generally data charge retention time vs. reciprocal temperature for point defect traps in a silicon dioxide insulator, parameterized for three different values of trap energy.

FIG. 4 is a block diagram illustrating generally one embodiment of a memory device that includes a memory cell according to the teachings of the present invention.

FIG. 5 is a drawing that illustrates generally, by way of example, but not by way of limitation, one embodiment of a computer system according to the present invention.



## DETAILED DESCRIPTION OF THE INVENTION

In the following detailed description of the invention, reference is made to the accompanying drawings which form a part hereof, and in which is shown, by way of illustration, specific embodiments in which the invention may be practiced. In the drawings, like numerals describe substantially similar components throughout the several views. These embodiments are described in sufficient detail to enable those skilled in the art to practice the invention. Other embodiments may be utilized and structural, logical, and electrical changes may be made without departing from the scope of the present invention. The terms wafer and substrate used in the following description include any structure having an exposed surface with which to form the integrated circuit structure of the invention. The term substrate is understood to include semiconductor wafers. The term substrate is also used to refer to semiconductor structures during processing, and may include other layers that have been fabricated thereupon. Both wafer and substrate include doped and undoped semiconductors, epitaxial semiconductor layers supported by a base semiconductor or insulator, as well as other semiconductor structures well known to one skilled in the art. The term conductor is understood to include semiconductors, and the term insulator is defined to include any material that is less electrically conductive than the materials referred to as conductors. The following detailed description is, therefore, not to be taken in a limiting sense, and the scope of the present invention is defined only by the appended claims, along with the full scope of equivalents to which such claims are entitled.

FIG. 1 is a schematic diagram illustrating generally, by way of example, but not by way of limitation, one embodiment of a memory cell **100** according to one aspect of the present invention. Memory cell **100** is illustrated, by way of example, as a flash memory cell. However, memory cell **100** also includes, but is not limited to, a dynamic random access memory (DRAM) cell, a nonvolatile random access memory (NVRAM) cell, an electrically alterable read-only memory (EAROM) cell, a dynamic electrically alterable programmable read-only memory (DEAPROM), and any other similar memory cell providing either nonvolatile or volatile, binary or multi-state (e.g., digital or quantized analog) data storage.

Memory cell **100** includes a field-effect transistor (FET) **105** having a floating (i.e., electrically isolated) gate **110**, a control gate **115**, a source **120**, and a drain **125**. Following established convention, the terminals associated with the terms "source" and "drain" are actually determined by operating conditions of FET **105** (i.e., source **120** and drain **125** are interchangeable). A gate insulator **130** is interposed between control gate **115** and a channel region **135** is formed in a substrate between source **120** and drain **125**. Memory cell **100** is addressed by word line **140**, or any other conductor that is electrically coupled to control gate **115**. Data in memory cell **100** is accessed through data line **145**, or any other conductor that is electrically coupled to drain **125**.

According to one aspect of the invention, floating gate **110** includes at least one trap site, such as a point defect trap site, capable of receiving and storing an electron. According to another aspect of the invention, floating gate **110** includes a plurality of trap sites, such as point defect trap sites, each trap site capable of receiving and storing only a single electron. The trap sites are electrically isolated from each other. In the absence of an externally applied electric field,

the stored electrons are substantially confined to their respective trap sites. According to another aspect of the invention, the trap sites are distributed at a density such that the trap sites are substantially shielded from each other by intervening portions of the gate insulator **130**.

FIG. 2 is a cross-sectional diagram illustrating generally, by way of example, but not by way of limitation, one embodiment of transistor, such as FET **105** in memory cell **100**, according to one aspect of the present invention. In one embodiment, gate insulator **130** is formed from amorphous silicon dioxide. In other embodiments, gate insulator **130** is formed from other materials, including, but not limited to: quartz, aluminum trioxide, titanium dioxide, lithium niobate, silicon nitride, and diamond.

In FIG. 2, floating gate **110** includes point defect trap sites **200**. Each one of trap sites **200** is generally capable of receiving and storing only a single electron. In one embodiment, the trap sites have a cross-sectional area of capture of approximately  $10^{-15}$  cm<sup>2</sup>. A number of different techniques are used to form trap sites **200** according to the present invention. According to one aspect of the present invention, for example, process conditions of existing semiconductor fabrication steps are adjusted to obtain the desired trap sites **200**. In one embodiment, gate insulator **130** is formed of silicon dioxide. The silicon dioxide is formed by thermal oxidation of a silicon substrate **205**. In this embodiment, the oxidizing ambient is adjusted between O<sub>2</sub> (dry oxidation) and H<sub>2</sub>O vapor (wet oxidation) to obtain the desired density of trap sites **200**. Alternatively, or in combination with the above-described oxidation techniques, a subsequent annealing time and annealing ambient are varied to obtain the desired density of trap sites **200**.

In another embodiment, trap sites **200** are formed by ion-implantation of impurities, such as aluminum (Al), silicon (Si), or arsenic (As), into gate insulator **130**. Other species of impurities may also be used. According to one aspect of the invention, the ion-implantation energy is adjusted such that the trap sites **200** are generally implanted at a distance (d) from substrate, where d is approximately 1/3 of the thickness of the insulator between control gate **115** and substrate **205**. A resulting approximately Gaussian distribution of trap sites **200** is thereby located relatively close to the interface between gate insulator **130** and substrate **205**. According to another aspect of the invention, an ion-implant dose is adjusted for low-density disposition of the trap sites **200**, such that the trap sites **200** are generally substantially shielded from each other by intervening portions of gate insulator **130**. In one embodiment, the areal concentration of trap sites is approximately between  $10^{12}$  and  $10^{15}$  trap sites **200** per cm<sup>2</sup>. As a result, particular ones of the trap sites **200** do not substantially overlap others of the trap sites **200**. In one embodiment, the concentration of the trap sites is adjusted to avoid agglomeration of point defect trap sites **200** into nanocrystals of the implanted impurity.

As described above, one aspect of the invention includes a distribution of point defect trap sites **200** serving as a floating gate **110**. The trap sites **200** are distinguishable from a conventional floating gate transistor having a continuous conductor as an electrically isolated floating gate. For example, conventional floating gate transistors typically utilize Fowler-Nordheim tunneling for transporting charge from a floating gate to the underlying channel. By contrast, one aspect of a transistor having a floating gate comprising point defect trap sites is that it is characterized by Price-Sah tunneling for transporting charge from the point defects to the underlying channel. See, e.g., L. Forbes et al., "Tunneling and Thermal Emission of Electrons at Room Tempera-

ture and Above from a Distribution of Deep Traps in SiO<sub>2</sub>," *IEEE Trans. On Electron Devices*, Vol. 40, No. 6, pp. 1100–1103, (June 1993) and T. Nishida et al., "Tunneling and Thermal Emission of Electrons from a Distribution of Shallow Traps in SiO<sub>2</sub>," *Appl. Phys. Lett.*, Vol. 58, pp. 1262–64 (1991).

The point defect trap sites **200** are also distinguishable from a floating gate comprising a distribution of conductive elements, such as silicon nanocrystals, in a gate insulator, such as described in the co-pending, commonly assigned U.S. patent application "A MULTI-STATE FLASH MEMORY CELL AND METHOD FOR PROGRAMMING SINGLE ELECTRON DIFFERENCES," Ser. No. 08/790, 903, filed on Jan. 29, 1997, which disclosure is herein incorporated by reference. Nanocrystalline silicon grains have a finite grain size that may vary between individual grains. As a result, the capacitance of individual grains may vary between individual grains. Even if such grains are capable of storing only a single electron, the resulting voltage on any particular grain may depend on the grain size. As electrons are being stored on respective grains (e.g., to represent a digital data input or an analog data input), the resulting drain current may change in irregularly sized steps. By contrast, the point defect trap sites **200** according to the present invention do not have a variable grain size, capacitance, and resulting voltage. As electrons are being stored on their respective point defects, the drain current changes in more regularly sized steps, allowing easy differentiation between memory states, such as memory states differing by only a single stored electron.

The point defect trap sites **200** are also distinguishable from a floating gate comprising a heterostructure, such as a graded bandgap structures in which several electrons are stored in a localized potential minimum. Point defect trap sites **200** allow storage of only a single electron. For a particular number of memory states, less charge must be transported to the point defect trap sites **200** than to one or more heterostructure potential minima. As a result, the present invention reduces oxide fatigue and increases the reliability and cyclability of the FET memory cell **100**.

According to one aspect of the present invention, the trap sites **200** are selected to have a particular trap energy for obtaining a desired data charge retention time (i.e., the average time that an electron is retained on the point defect trap site for a particular temperature) and for minimizing erasure time (i.e., how long it takes to remove approximately all of the stored electrons from respective point defect trap sites by applying a large negative voltage to the control gate of the FET). The data charge retention time is determined by the rate at which electrons are thermally emitted from the trap sites **200**, which is described by Arrhenius Equation 1.

$$R_e = B e^{\left(-\frac{E}{kT}\right)} \quad (1)$$

In Equation 1,  $R_e$  is the thermally activated emission rate from the traps (in reciprocal units of time), B is a constant that is approximately independent of temperature, E is the trap energy as measured from the conduction band of the host insulator, k is Boltzman's constant, and T is absolute temperature in degrees Kelvin. B and E both depend on the detailed physical nature of the trap and the host insulator.

FIG. 3 is a graph illustrating generally data charge retention time **300** vs. reciprocal temperature **305** for point defect trap sites **200** in a silicon dioxide insulator, parameterized for three different values of trap energy. Data charge retention time **300** is illustrated in units of seconds. Reciprocal

temperature is illustrated in units of 1000/T, where T is absolute temperature in degrees Kelvin. Line **310** illustrates generalized experimental data from point defect traps having an average energy of approximately 1.5 eV, as set forth in L. Forbes et al., "Tunneling and Thermal Emission of Electrons at Room Temperature and Above from a Distribution of Deep Traps in SiO<sub>2</sub>," *IEEE Trans. On Electron Devices*, Vol. 40, No. 6, pp. 1100–1103, (June 1993). Line **310** yields an approximate value of  $B=1.8 \times 10^{18}$ . Line **315** illustrates values calculated from Equation 1, using  $B=1.8 \times 10^{18}$  and a trap energy of  $E=1.3$  eV. Line **320** illustrates values calculated from Equation 1, using  $B=1.8 \times 10^{18}$  and a trap energy of  $E=2.4$  eV.

In one embodiment of the present invention, the graph of FIG. 3 is used to select a particular trap energy for obtaining the desired data charge retention time. Point defect trap sites **200** having the desired trap energy are formed, such as using the processing techniques described above, or any other suitable processing technique for obtaining the desired trap energy and corresponding data charge retention time.

For example, by selecting a trap energy of  $E=1.5$  eV, as illustrated by line **310**, a data charge retention time estimated at approximately 10 million seconds (2800 hours) is obtained at point **325** at a temperature of approximately 300 degrees Kelvin (27 degrees Celsius). A data charge retention time estimated at approximately 6000 seconds (approximately 1.6 hours) is obtained at point **330** at a temperature of 358 degrees Kelvin (85 degrees Celsius), which corresponds to the highest operating temperature for which commercial semiconductor components are typically designed.

In another example, by selecting a trap energy of  $E=2.4$  eV, as illustrated by line **320**, a data charge retention time estimated at approximately  $10^{14}$  seconds (approximately 3 million years) is obtained at point **335** at a temperature of 358 degrees Kelvin (85 degrees Celsius). At lower temperatures, longer data charge retention times are obtained. The long data charge retention times obtained from this embodiment of memory cell **100** provide nonvolatile data storage functionality that is comparable to an EEPROM or magnetic hard disk drive memory. According to another aspect of this embodiment of the present invention, the desired trap energy is also selected based on a desired maximum tolerable erase time (e.g., in the range of approximately 1 second) when a negative erase voltage is applied to control gate **115** to eject electrons from trap sites **200**.

In another example, by selecting a trap energy of  $E=1.3$  eV, as illustrated by line **315**, a data charge retention time of approximately 1 second is obtained at point **340** at a temperature of 358 degrees Kelvin (85 degrees Celsius). At lower temperatures, longer data charge retention times are obtained. The data charge retention times obtained from this embodiment of memory cell **100** provide volatile data storage functionality that is comparable to a DRAM memory. According to another aspect of this embodiment of the present invention, the desired trap energy is also selected based on a desired maximum tolerable erase time (e.g., in the range of approximately 1 millisecond) when a negative erase voltage is applied to control gate **115** to eject electrons from trap sites **200**.

Another aspect of the invention provides short write times for data storage. For example, in one embodiment, point defect trap sites **200** have a cross-sectional area of capture of approximately  $10^{-15}$  cm<sup>2</sup>. Charge is stored on trap sites **200** by hot electron injection. For example, by providing a hot electron injection gate current of approximately one micro-

ampere over an area of  $10^{-8}$  cm<sup>2</sup>, an electron flux of approximately  $10^{21}$  electrons/(cm<sup>2</sup>-sec) is obtained. Thus, resulting write times are approximately in the microsecond range, or even shorter.

According to one aspect of the invention, memory cell **100** is included in a memory device that provides two-state (binary) or multi-state data storage. FIG. **4** is a block diagram illustrating generally, by way of example, but not by way of limitation, one embodiment of a memory device **400** that includes memory cell **100** according to the teachings of the present invention. Memory device **400** includes first and second arrays **405** and **410** of memory cells **100**. Second array **410** stores the state of the memory cells **100** in first array **405** at a time prior to storing data in first array **405**. Thus, second array **410** provides a comparison basis during a read operation for determining the number of step changes in drain current induced during the programming of a memory cell **100** during a write operation.

Each memory cell **100** of first array **405** is associated with a memory cell **100** of second array **410**. The associated memory cells **100** may be accessed according to address signals provided by an external system such as a microprocessor, memory controller, or other external system. Address lines **415** are coupled to first and second word line decoders **420** and **425**, and first and second data line decoders **430** and **435**. First word line decoder **420** and first data line decoder **430** are coupled to first array **405**. Similarly, second word line decoder **425** and second data line decoder **435** are coupled to second array **410**. First and second sense amplifiers **440** and **450** are coupled to first and second data line decoders **430** and **435**, respectively. Read circuit **460** is coupled to first and second sense amplifiers **440** and **450**. Read circuit **460** provides the output of memory device **400**.

In operation, memory device **400** writes, reads and erases multiple bits in each memory cell **100** storage location of first array **405**.

In write mode, memory device **400** receives an address on address line **415**. Word line decoders **420** and **425** decode the associated word line **140** for a selected memory cell **100** and activate the corresponding word line **140**. Data line decoders **430** and **435** similarly decode the data line **145** for the desired memory cell **100**. The data state of the selected memory cell **100** in first array **405** is stored in the associated memory cell **100** in second array **410**. The selected memory cell **100** in first array **405** is then programmed to a selected state to store a value that represents a number of bits.

In read mode, the address of the selected memory cell **100** is similarly decoded and the associated memory cells **100** of first and second arrays **405** and **410**, respectively, are accessed. Data line decoders **430** and **435** couple the selected cell to sense amplifiers **440** and **450**, respectively. Read circuit **460** compares the stored value of the memory cell **100** from first array **405** with the initial state stored in the second array **410**. The comparison results in an output signal that represents the value of a number of bits.

FIG. **5** is a drawing that illustrates generally, by way of example, but not by way of limitation, one embodiment of a computer system **500** according to the present invention. In one embodiment, computer system **500** includes a monitor **505** or other communication output device, a keyboard **510** or other communication input device, as well as a motherboard **515**, carrying a microprocessor **520** or other data processing unit and at least one memory device **400**.

#### CONCLUSION

The invention provides, among other things, a memory cell that uses point defect trap sites in an insulator for storing

charge representing binary or multi-state data in volatile and nonvolatile memories. As additional electrons are stored upon the point defect trap sites, more uniform changes in drain current result. Memory states differing by only a single stored electron are more easily distinguished during a read operation. Oxide fatigue is reduced. The reliability and cyclability of memory cell is increased.

It is to be understood that the above description is intended to be illustrative, and not restrictive. Many other embodiments will be apparent to those of skill in the art upon reviewing the above description. The scope of the invention should, therefore, be determined with reference to the appended claims, along with the full scope of equivalents to which such claims are entitled.

What is claimed is:

1. A method of storing and retrieving data, the method comprising:

altering the number of electrons stored on a memory cell in trap sites carried by an insulator at a density such that the trap sites are substantially shielded from each other by intervening portions of the insulator; and

detecting a resulting parameter based on the number of electrons stored in the trap sites, wherein the parameter is selected from the group consisting of current, voltage, and charge.

2. The method of claim 1, wherein altering the number of electrons stored on a memory cell includes injecting electrons onto the trap sites.

3. The method of claim 2, wherein injecting electrons onto the trap sites is by hot-electron injection.

4. The method of claim 1, wherein altering the number of electrons stored on a memory cell includes removing electrons from the trap sites.

5. The method of claim 4, wherein removing electrons from the trap sites is by Price-Sah tunneling.

6. The method of claim 1, further comprising the step of reading a data state based on the detected resulting parameter.

7. The method of claim 1, further comprising the step of reading a number of possible data states based on the detected resulting parameter, wherein the number of possible data states corresponds to the number of trap sites.

8. The method of claim 1, wherein altering the number of electrons is based on a digital input.

9. The method of claim 1, wherein altering the number of electrons is based on an analog input.

10. A method of storing and retrieving data, the method comprising:

altering the number of electrons stored on a memory cell in trap sites carried by an insulator at a density such that the trap sites are substantially shielded from each other by intervening portions of the insulator and wherein the trap sites are capable of capturing no more than one electron; and

detecting a resulting parameter based on the number of electrons stored in the trap sites, wherein the parameter is selected from the group consisting of current, voltage, and charge.

11. The method of claim 10 wherein altering the number of electrons stored on a memory cell includes injecting electrons onto the trap sites.

12. The method of claim 11, wherein injecting electrons onto the trap sites is by hot-electron injection.

**9**

**13.** The method of claim **10**, wherein altering the number of electrons stored on a memory cell includes removing electrons from the trap sites.

**14.** The method of claim **13**, wherein removing electrons from the trap sites is by Price-Sah tunneling.

**15.** The method of claim **10**, further comprising the step of reading a data state based on the detected resulting parameter.

**16.** The method of claim **10**, further comprising the step of reading a number of possible data states based on the

**10**

detected resulting parameter, wherein the number of possible data states corresponds to the number of trap sites.

**17.** The method of claim **10**, wherein altering the number of electrons is based on a digital input.

**18.** The method of claim **10**, wherein altering the number of electrons is based on an analog input.

\* \* \* \* \*